



ALCHEMY 5

THE NEW GENERATION

FRESNEL LED WASH LIGHT

DTS' 6-COLOR LED ENGINE EVOLUTION

ALCHEMY 5 - SPECTRAL DISTRIBUTION

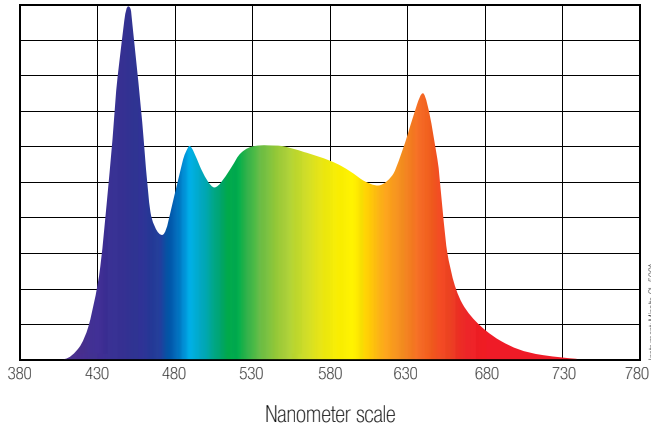

Thanks to a custom 6-color LED engine ALCHEMY 5 is able to deliver a High-Quality Spectrum: DTS' HQS trademark identifies the ability to generate a superior white light and a much broader color gamut than traditional RGBW color synthesis, with pastel shades and rich warm nuances.

CIE 1931 COLOR SPACE: COLOR GAMUT

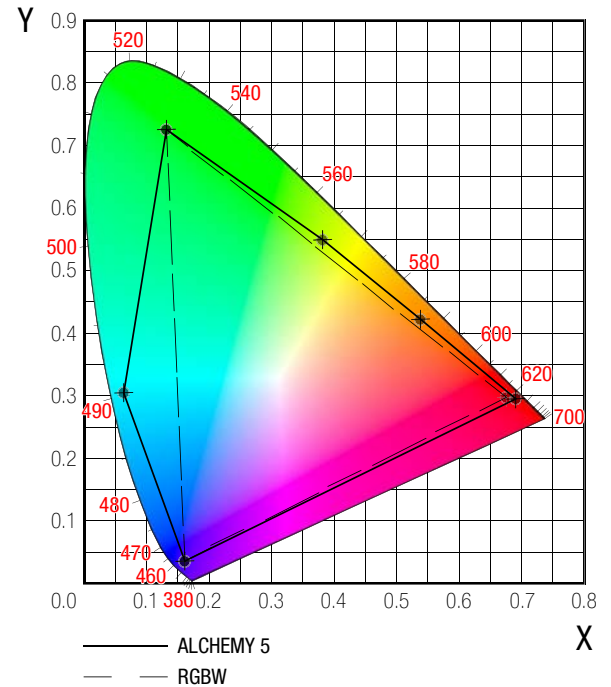

CIE 1931 COLOR SPACE: BLACK BODY LOCUS

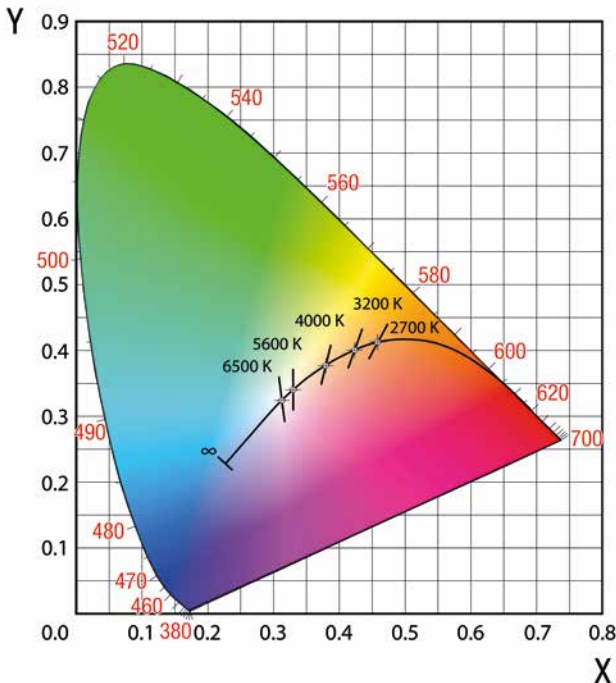

SUPERIOR WHITE LIGHT QUALITY

ALCHEMY 5 uses the most innovative technologies available on the market to generate great uniform white light: the measurements taken on Alchemy 5's whites match the black body locus coordinates almost perfectly. To fit any need Alchemy 5 offers technical functions to fine-tune whites:

* The **CCT linear control** from 1,800 K to 10,000 K allows to meet any camera or production requirement.

* The linearly adjustable **green / magenta point**: useful for adapting to any complexion shade, or different light sources.

TOP PERFORMANCE

ALCHEMY 5 provides professional features suitable for theatres and television studios.



With its large **Ø 250 mm Fresnel lens** coupled with a **10° - 47° linear zoom**, ALCHEMY 5 can project an extra-bright light beam, evenly diffused with any zoom angle.

Moreover, the fixture is equipped with specific accessories and functions that complete its perfect usability:

* The **'Hi-Q dimming'** technology guarantees perfectly linear fade-in and fade-out at all dimming levels.

* Two DMX-selectable **frost filters** (light / heavy) enable to change from hard-edge to a choice of soft-edge projections.

* A **beam shaper** (2 x 1 ratio) with endless indexable rotation.

* A **motorized top hat** avoids any glare and retracts automatically when the fixture is switched off.

* **'Silent' mode** designed for theatres and TV studios: the measured noise level is only 37 dBA @ 1 m (normal operation, full power).



ADVANCED COLOR GENERATION

Gel filter emulation.

Choose any of the 100 digital emulations of the most used gel filters.



Linear balance from gel filters emulation to white.

The gel emulations can be shifted from full color back to CCT by setting the desaturation level. This generates countless variations of color.



Example: 126 Mauve to White 3200 K

Linear balance between gel filters emulation.

Alchemy 5 allows to cross-fade between any gel filter and another, creating a world of dynamically changing colors.



Example: 777 Rust to 202 Half C.T. Blue

True color of gel filters emulation at any CCT value.

Gel filters' color response fully adapts to different CCT values.

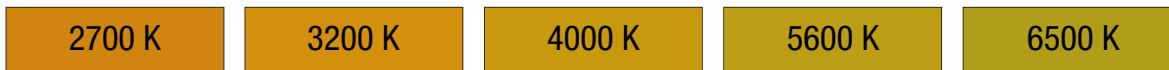

Example: 100 Spring yellow

Extra deep colors.

Deep blue and Deep red filters can be selected via DMX to further extend the range of colors generated by the multi-chip LED, enlarging the two ends of the visible spectrum.

Custom color creation.

Furthermore, ALCHEMY 5 allows to create any color from scratch, using the 6-color 'Advanced' (RAW) mode.



DTS' HQS trademark identifies the ability to generate a superior white light and a much broader color gamut than traditional RGBW color synthesis, with pastel shades and rich warm nuances.

Technical specifications

OUTPUT

- Multi-chip LED source (10,800 Lumen output)
- CRI: up to 98
- TLCI: up to 96
- LED source lifespan: 20,000 hours (70% Lumen output)

OPTICAL GROUP

- Ø 250 mm Fresnel lens
- 10° - 47° linear zoom
- Indexable beam shaper with endless rotation (2 x 1 ratio)
- 2 frost filters (soft and heavy) insertable via DMX
- Retractable 'top hat'

WHITE / COLOR GENERATION

- 6-color LED engine
- Linear CCT (1,800 K - 10,000 K)
- Linear 'Green saturation'

- 100 gel filter emulations
- Linear balance from gel filters emulation to white
- Linear balance between gel filters emulation
- True color of gel filters emulation at any CCT values
- Color mixing by 6-color 'Advanced' (RAW) mode
- Deep blue and Deep red filters (DMX-selectable)
- 'Hi-Q Dimming' technology

CONTROL

- LCD graphic display + 4 soft-keys; Auto-flip; Key-Lock function
- Art-Net 4, sACN, RDM/DMX 512 protocols
- 2 operation modes: 'Standard' or 'Silent' (designed for theatres and TV studios)
- Internal operating system updatable via DTS dongle firmware uploader
- Li-Fe backup battery for controlling the display settings even when the unit is not powered

DMX

- 4 DMX modes:
 - _ CCT + Gel colors (default)
 - _ Advanced (RAW)
 - _ Basic
 - _ Expo

PAN & TILT

- Pan: 540°: 3.8 sec. / Tilt: 220°: 2.1 sec. (max speed)
- 16-bit resolution
- Pan / Tilt lock

POWER SUPPLY

- Electronic full-range 100-277Vac 50-60 Hz
- Power consumption: 450 W max
- Power Factor: PF >0.90

CONNECTIONS

- Power supply: PowerCON TRUE1 In/Out panel connectors
- DMX: XLR 3-pole and 5-pole In/Out panel connectors
- Art-Net / sACN: etherCON RJ45 connector

INTERNAL SAFETY DEVICES

- Overvoltage and overtemperature circuits protection

OPERATING TEMPERATURE

- -10° / 45° C

PHYSICAL

- IP20
- Weight: 26.5 Kg (58 lbs)
- Finishing: Black

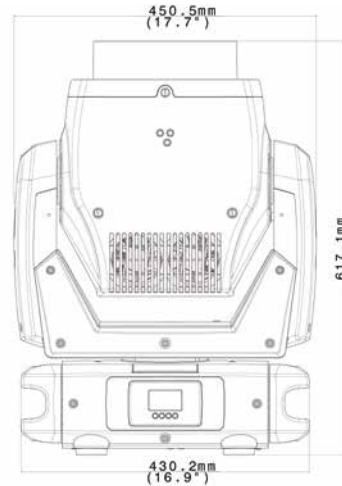
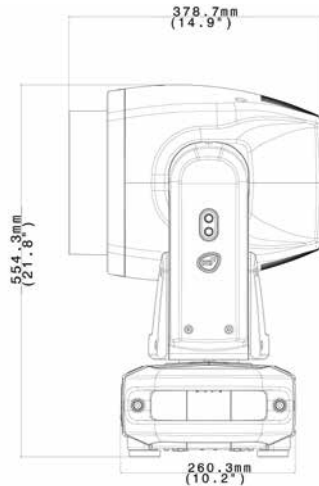

ALCHEMY 5 Beam angle 10° @ 50%

Distance (m)	5	10	15	20	25
Distance (ft)	16.40	32.81	49.31	65.62	82.02
lux center	7000	1750	778	438	280
Foot candles	651	163	72	41	26
lux center	8875	2219	986	555	355
Foot candles	825	206	92	52	33
lux center	10100	2525	1122	631	404
Foot candles	939	235	104	59	38
Diameter cm	87	175	262	350	437
Diameter ft	3	6	9	11	14

WHITE 3200 K

WHITE 4000 K

WHITE 5600 K

ALCHEMY 5 Beam angle 47° @ 10%

Distance (m)	5	10	15	20	25
Distance (ft)	16.40	32.81	49.31	65.62	82.02
lux center	1500	375	167	94	60
Foot candles	139	35	15	9	6
lux center	1720	430	191	108	69
Foot candles	160	40	18	10	6
lux center	1967	492	219	123	79
Foot candles	183	46	20	11	7
Diameter cm	435	870	1304	1739	2174
Diameter ft	14	29	43	57	71

WHITE 3200 K

WHITE 4000 K

WHITE 5600 K



D.T.S. Illuminazione srl
via Fagnano Selve 12/14
47843 Misano Adriatico (RN)
ITALY

Phone + 39 0541 611131
Fax + 39 0541 611111
Email info@dts-lighting.it
dts-lighting.it