

MAX



User's Manual rel 1.0 GB



The Lighting Company

Le informazioni contenute in questo documento sono state attentamente redatte e controllate. Tuttavia non è assunta alcuna responsabilità per eventuali inesattezze. Tutti i diritti sono riservati e questo documento non può essere copiato, fotocopiato, riprodotto per intero o in parte senza previo consenso scritto della D.T.S .

D.T.S. si riserva il diritto di apportare senza preavviso cambiamenti e modifiche estetiche , funzionali o di design a ciascun proprio prodotto. D.T.S non assume alcuna responsabilità sull'uso o sull'applicazione dei prodotti o dei circuiti descritti.

The information contained in this publication has been carefully prepared and checked. However, no responsibility will be taken for any errors. All rights are reserved and this document cannot be copied, photocopied or reproduced, in part or completely, without prior written consent from D.T.S.

D.T.S. reserves the right to make any aesthetic, functional or design modifications to any of its products without prior notice. D.T.S. assumes no responsibility for the use or application of the products or circuits described herein.

Les informations contenues dans le présent manuel ont été rédigées et contrôlées avec le plus grand soin. Nous déclinons toutefois toute responsabilité en cas d'éventuelles inexactitudes. Tous droits réservés. Ce document ne peut être copié, photocopié ou reproduit, dans sa totalité ou partiellement, sans le consentement préalable de D.T.S.

D.T.S. se réserve le droit d'apporter toutes modifications et améliorations esthétiques, fonctionnelles ou de design, sans préavis, à chacun de ses produits. D.T.S. décline toute responsabilité sur l'utilisation ou sur l'application des produits ou des circuits décrits.

Las informaciones contenidas en este documento han sido cuidadosamente redactadas y controladas. Con todo, no se asume ninguna responsabilidad por eventuales inexactitudes. Todos los derechos han sido reservados y este documento no puede ser copiado, fotocopiado o reproducido, total o parcialmente, sin previa autorización escrita de D.T.S.

D.T.S. se reserva el derecho a aportar sin previo aviso cambios y modificaciones de carácter estético, funcional o de diseño a cada producto suyo. D.T.S. no se asume responsabilidad de ningún tipo sobre la utilización o sobre la aplicación de los productos o de los circuitos descritos.

INDEX:

1- SYMBOLS	4
2- GENERAL WARNING	5
3- GENERAL WARRANTY CONDITIONS	5
4- TECHNICAL FEATURES	5
5- ACCESSORIES	7
6- IMPORTANT SAFETY INFORMATION	8
6.1 Fire prevention.....	8
6.2 Prevention of electric shock.....	8
6.3 Protection against ultraviolet radiation.....	8
6.4 Safety	8
6.5 Level of protection against the penetration of solid and liquid objects	8
7- MOUNTING / REPLACING THE LAMP	9
8- VOLTAGE AND FREQUENCY	13
9- INSTALLATION	13
9.1 Safety cable.....	15
9.2 Protection against liquids.....	15
9.3 Movement.....	16
9.4 Risk of fire	16
9.5 Forced ventilation	16
9.6 Ambient temperature	16
10- MAINS CONNECTION	17
10.1 Protection	17
11- DMX SIGNAL CONNECTION	18
11.1 DMX addresses	18
11.2 Selecting the DMX address	18
12- FIRMWARE UPDATING	19
13- DISPLAY FUNCTIONS	20
14- ERROR MESSAGES	25
15- HIDDEN MENU	26
15.1 Calibration mode	26
16- PAN & TILT SPEED	28
17- OPENING THE PROJECTOR HOUSING	28
18- PERIODIC CLEANING	29
18.1 Lenses and reflectors	29
18.1 Fans and air passages	29
19- PERIODIC CONTROLS	29
20- DMX PROTOCOL	30
21- ROTATING GOBO WHEEL	41
22- FIXED GOBO WHEEL	42
23- COLOUR WHEEL	43

1- SYMBOLS

Graphic symbols used on this manual:



THIS SYMBOL INDICATES A HOT SURFACE

t_c 80°C

THIS SYMBOL INDICATES TEMPERATURE OF THE EXTERNAL SURFACE



THIS SYMBOL INDICATES ELECTRIC SHOCK RISK

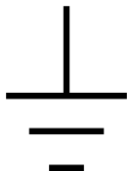

THIS SYMBOL INDICATES PROTECTION AGAINST ELECTRICAL SHOCK



THIS SYMBOL INDICATES GENERAL RISK



THIS SYMBOL MEANS YOU CAN PLACE THE UNIT ON NORMALLY FLAMMABLE SURFACES



THIS SYMBOL MEANS “RADIATION FROM THIS LAMP CAN CAUSE DAMAGE TO EYES AND SKIN”



THIS SYMBOL INDICATES THE MINIMUM DISTANCE FROM THE ILLUMINATED OBJECTS

2- GENERAL WARNING

Read the instruction contained in this user manual carefully, as they give important information regarding safety during installation, use and maintenance.

The device is not for domestic use and must be installed by a qualified electrician or experienced person.

Always disconnect the device from the mains before replacing the lamp.

The lamp must be replaced if it has been damaged or deformed by prolonged use or overheating.

The device must always be equipped with an efficient ground connection.

3- GENERAL WARRANTY CONDITIONS

The unit is guaranteed for 36 months from the date of purchase against manufacturing material defects.

4- TECHNICAL FEATURES

Overview

MAX L is a brand new model in the D.T.S. high-power compact moving heads line. MAX L features the same innovative technology of MAX, and addresses a range of top level applications: from concerts to special events; from television studios to theatres.

MAX L light output is comparable to the most powerful fixtures.

MAX L features a special optical group with wide excursion motorized zoom that for the first time allows 4 different types of projection in a single moving head: 'Beam', 'Spot', 'Wash', and 'Studio'.

No need to stock a whole range of lights: MAX L does it all.

In fact, MAX L wide excursion motorized zoom allows any application from long-throw projections to large wall washing.

Beam opening is: 1.7° 'Beam' projection; 1.7° - 37° 'Spot' projection; 10° - 60° 'Wash' projection. But MAX L introduces also the 'Studio' projection (3° - 40°), selectable via DMX; thanks to it, MAX L projects a beam so uniform and evenly diffused as never before.

Also, MAX L is very compact and light weight, the perfect moving head for rental companies who want a quick and easy to install unit.

MAX L

(D.T.S. Product Code: 03.MS015.EB.L)

• Electronic ballast 90-260V 50/60 Hz • Black finish

Lamp

MSD PLATINUM 16R 330W (16.000 Lumens)

Colour temperature: 8.000°K typ.

Type of connection: PINS 2,8 x 0,8 mm

Remote lamp On-Off

Average lamp life: 1.500 hrs

Optical group

Improved optical group made with 11 coated lenses

110.000 Lux at 5 m

Motorized wide-excursion linear zoom (1,7° - 60°)

16-bit motorized linear focus

Linear dimmer / shutter / strobe (0,85 flash/sec to 10 flash/sec)

Colour generation

Colour wheel (17 colours + white) with linear selection for perfect 2-colour beams

Dynamic effects

Overlapping wheels for multiple effects:

Customizable rotating gobo wheel (9 gobos)

Customizable fixed gobo wheel (10 gobos)

4-facet rotating prism

On-Off Frost filter

Interface / Control / Programming

LCD graphic display + 4 soft-keys (control / management / monitoring of the main parameters)

RDM

ARTNET available on request

Wireless ready

Updatable internal operating system

DMX

24 (Default) or 18 DMX channels

Pan & Tilt

Pan 540° (2,5 sec.); Tilt 270° (1,5 sec.)

New Tri-phase stepper motor technology for ultra-fast and silent Pan & Tilt movements

16-bit resolution

Selectable speed ranges

Pan / Tilt lock

Power supply

Electronic ballast: 90-260V 50/60 Hz

Power consumption: 450W with PFC

Energy saving

Power saving mode (the lamp dims to 80% after shutter closure)

Connectors

DMX: 4x XLR connectors (3-pole In and Out; 5-pole In and Out) by Neutrik

Power supply: POWERCON connectors (Power In / Power Out) by Neutrik

Operating ambient temperature

-10° / 40°

Weight

19 Kg

Internal safety devices

Overvoltage circuit protection and overtemperature circuit protection

International certifications

Safety: EN 60598-1: 2009
EN 60598-2-17: 1989

EMC: EN 55015.2006

Dimensions

Packaging Dimensions (LxWxH)

520 x 520 x 610 mm

Weight: 24,1 Kg

Unit Dimensions (LxWxH)

395x410x600mm

Weight: 19 Kg

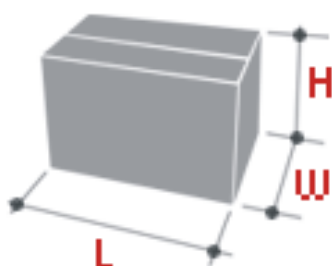

5- ACCESSORIES

As standard

- * 1 x MSD PLATINUM 16R 330W lamp (already installed in the projector) (Code 0505S036)
- * 1 x POWERCON male cable connector (Code 0520P014)
- * 1 x XLR 5 Pins male cable connector (Code 0508B066)
- * 1 x XLR 5 Pins female cable connector (Code 0508B065)
- * 2 x Omega clamp with "Fast Lock" connection 1/4 turn (Code 02K00549)
- * User's manual

Optional (on request)

- "C" Clamp G100 black / professional (max. load 200Kg) (Code 0521A015)
- Aliscaf Clamp (max. capacity load 100Kg) (Code 0521A008)
- Safety wire (3mm x 60 cm), ring spring catch, max. capacity load 60Kg (Code 0521A010)

6- IMPORTANT SAFETY INFORMATION

6.1 Fire prevention:

MAX L uses a MSD PLATINUM 16R 330W lamp.

The use of any other alternative lamp is not recommended and will null and void the fixture's warranty.



-It is permissible to place the unit on normally flammable surfaces.

Suitable for mounting on normally flammable materials surfaces greater than 200°C with some combustion time lag.

-Minimum distance from the closest illuminable surface: 2 m. 

-Replace any blown or damaged fuses only with those of identical value (6,3AT).

Refer to the wiring diagram if there is any doubt.

-Connect the projector to mains power via a thermal magnetic circuit breaker.

It is, moreover, recommended to protect the supply lines of the projectors from indirect contact and/or shorting to earth by using appropriately sized residual current devices.

6.2 Prevention of electric shock:



-High voltage is present inside the unit.

Unplug the unit prior to performing any function which involves touching the inside of the moving head, including lamp replacement.

-The level of technology inherent in the MAX L requires the assistance of specialised personnel for all servicing. Please refer to an authorised D.T.S. service centre.

-Connection must be made to a power supply system fitted with efficient earthing (Class I appliance).



-A good earth connection is essential for proper functioning of the projector.

-Never connect the unit without proper earth connection.

-The fixture should be located in places with a good air ventilation.

6.3 Protection against ultraviolet radiation:

-Never turn on the lamp if any of the lenses, filters or plastic covering are damaged. Their respective shielding functions will only operate efficiently if they are in perfect working order.



-Never look directly the lamp when it is on.

6.4 Safety:



-The projector should always be installed with bolts, clamps and other tools that are capable of supporting the weight of the unit.

-Always use a second safety cable to sustain the weight of the unit in case of the failure of the main fixing point.

-The maximum temperature that can be reached on the external surface of the unit, in a thermally steady state, is 80°C (176°F). t_c 80°C

Never handle the unit until at least 20 minutes have elapsed since the lamp was turned off.



-Always replace the lamp if any physical damage is evident.

-Never install the fixture in an enclosed area lacking sufficient air flow. The ambient temperature should not exceed 40°C.

-A hot lamp may explode, so always wait for at least 20 minutes prior to attempting to replace the lamp.

-Always wear suitable hand protection when handling the lamp.

6.5 Level of protection against the penetration of solid and liquid objects:



-The projector is classified as an ordinary appliance and its protection level against the penetration of solid and liquid objects is IP20.

For outdoor use, D.T.S. recommend the use of the dedicated raincovers.

7- MOUNTING / REPLACING THE LAMP



WARNING

Turn off the lamp before opening the unit head covers.
Never look directly at the lamp when it's lit.
Discharge lamps emits UV rays; radiation from this lamp
can cause damage to eyes and skin.

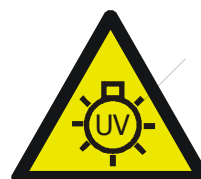

Switch off the unit and unplug the Mains AC cable connector.



Let the projector cool for at least 20 minutes
before replacing the lamp.



REPLACEMENT LAMP (D.T.S. Code 0505S036) :

MSD PLATINUM 16R
Power 330W
Luminous flux 16.000 lm
Colour temperature 8.000°K typ.
Rated life 1500 hours



The use of any other alternative lamp is not recommended and will null and void the fixture's warranty.

1) Loosen the 3 “¼ turn” screws which fix the head covers on both sides (picture 1) .

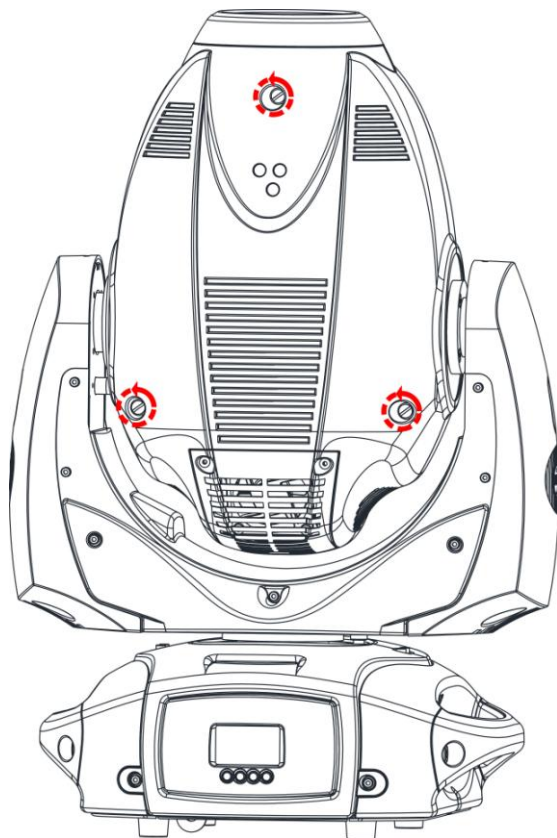

PICTURE 1

2) Once loosened the screws, simply lift the covers to access the internal components (picture 2).

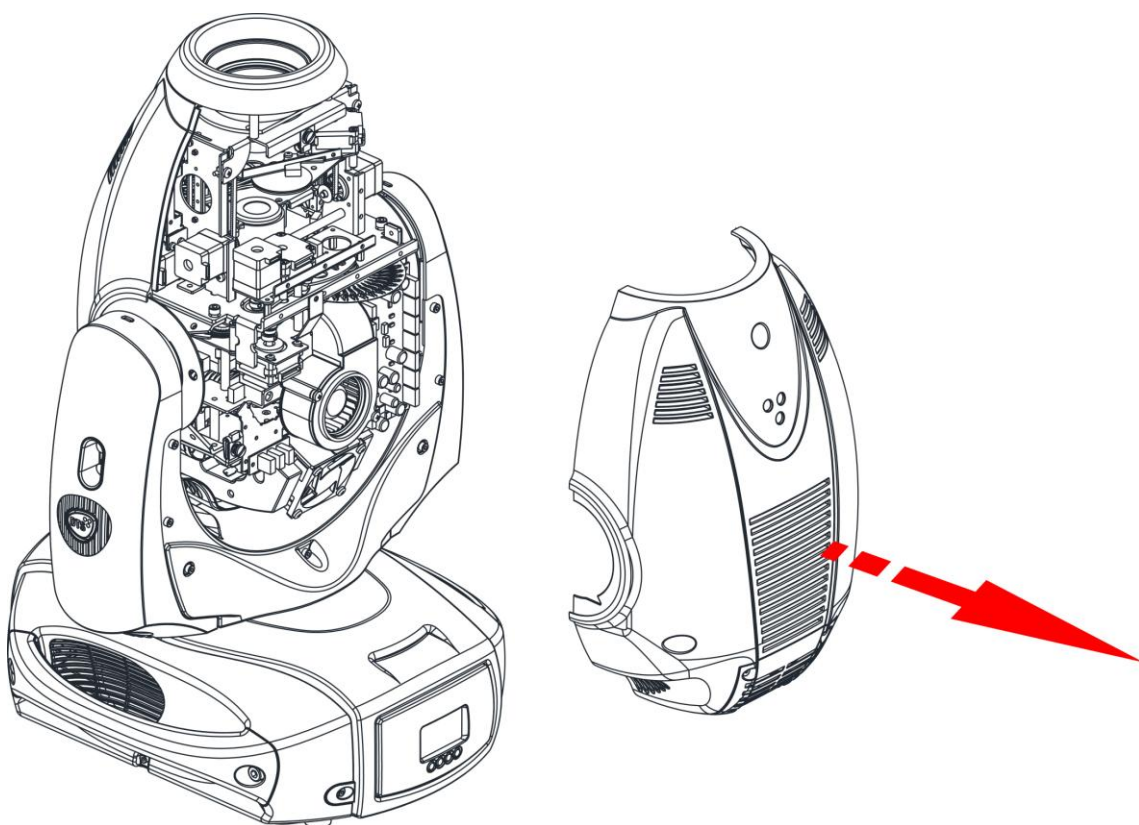

PICTURE 2

3) Using a phillips screwdriver, loose the indicated 2 screws which fix the lamp fan assembly on both sides and remove it (picture 3);

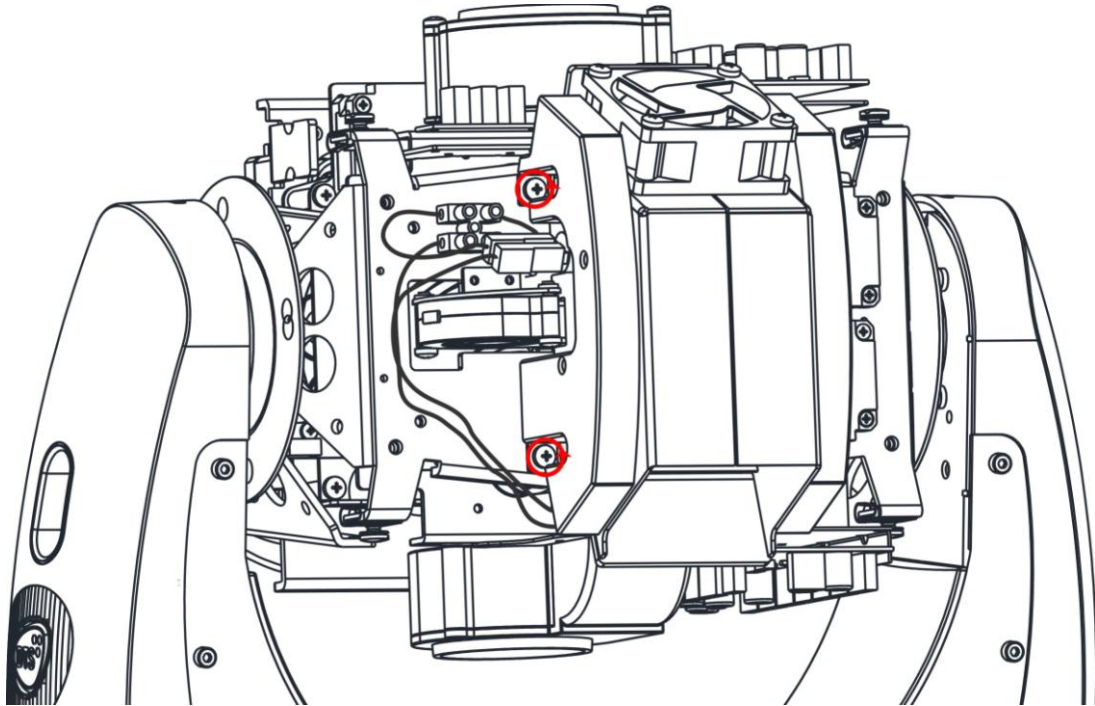

PICTURE 3

4) Unplug the two indicated fast-on cable connectors (picture 4), then loose the 4 screws from the metal plates that fix the old lamp (picture 5) and remove it.

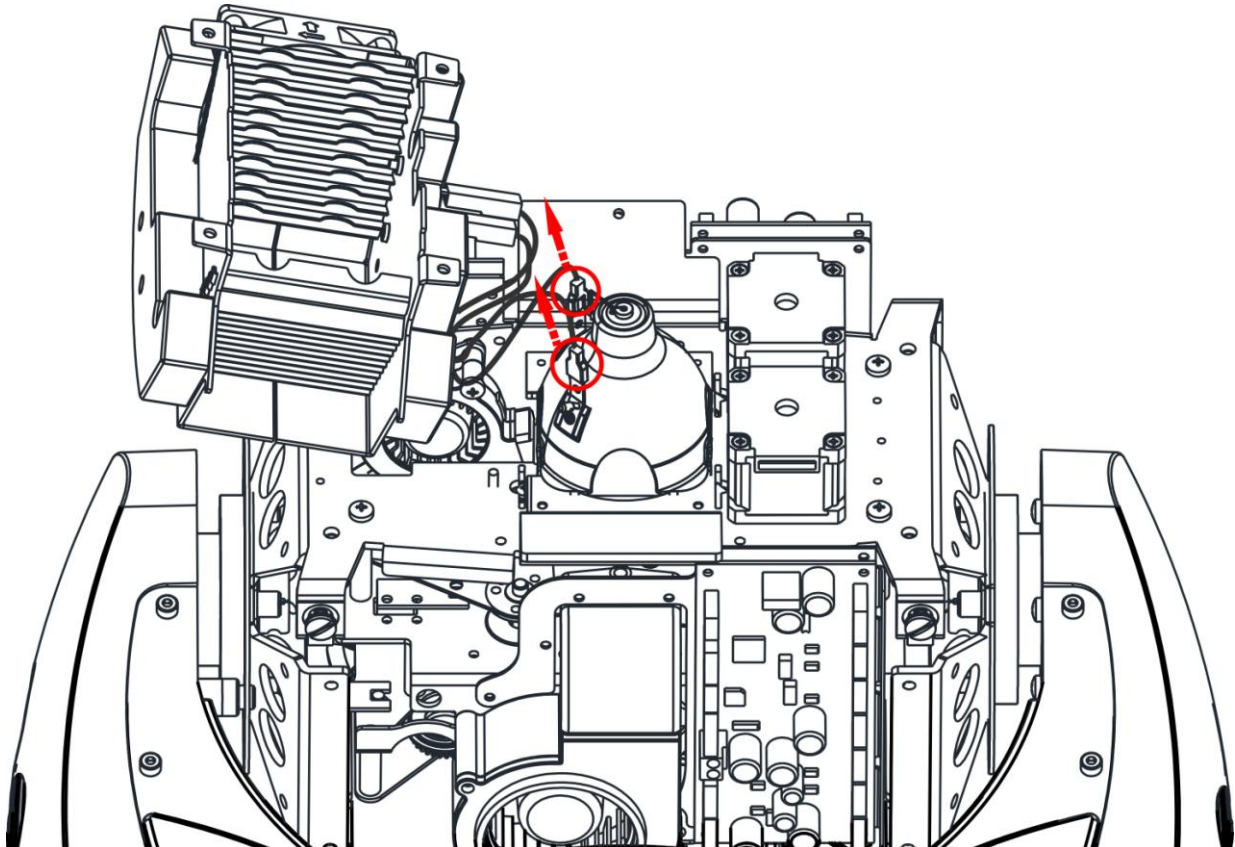

PICTURE 4

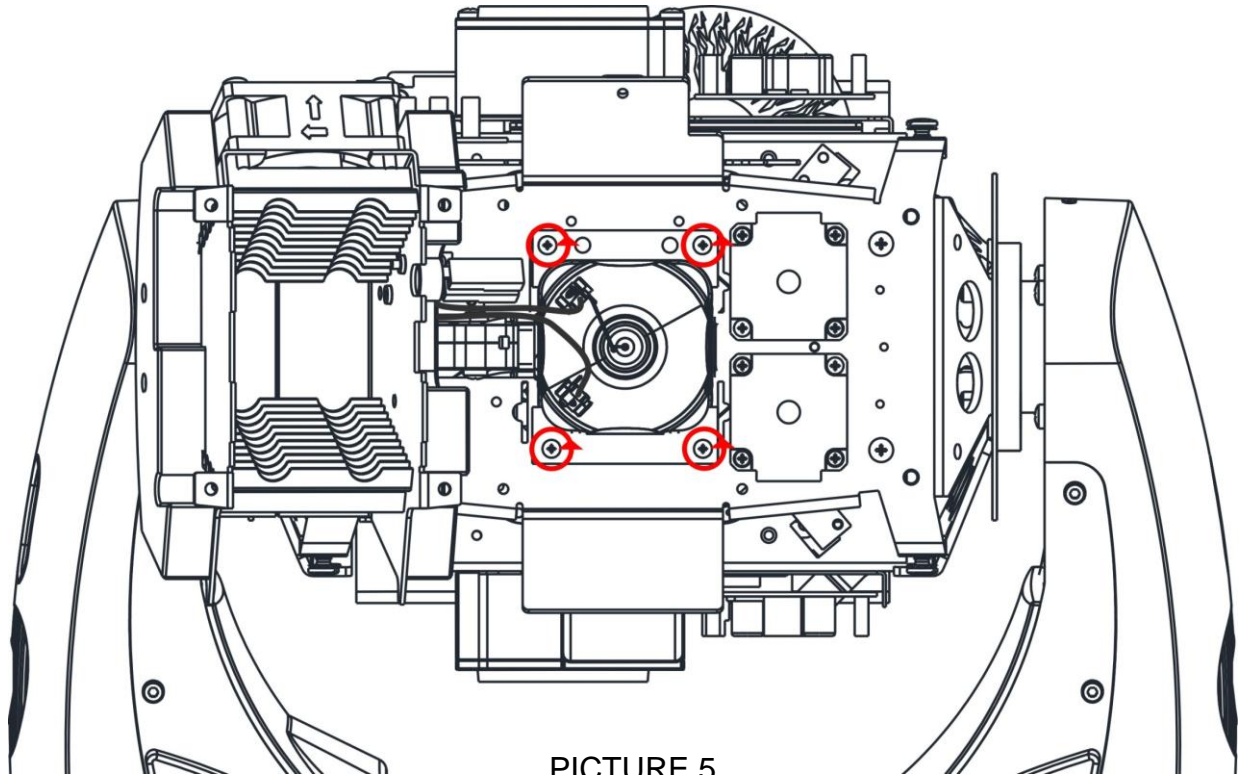

PICTURE 5

5) Put in place the new lamp in the lamp support.
Place the lamp terminals on the fan air conveyor side (Picture 6).

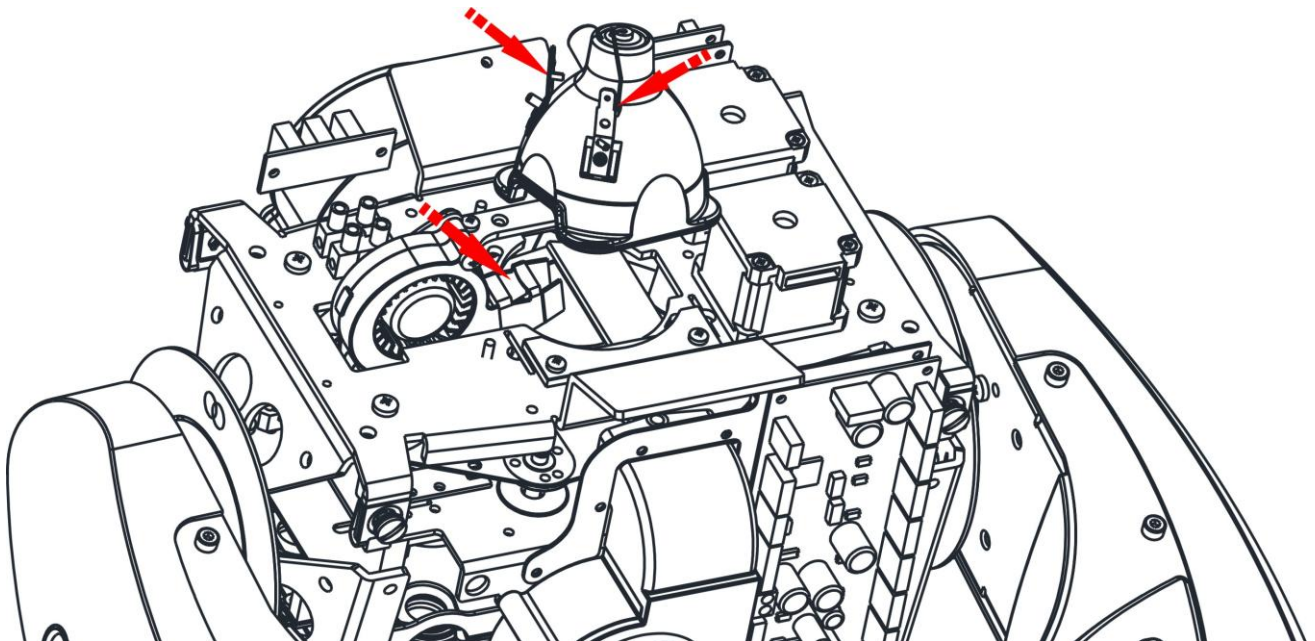

PICTURE 6

6) Lamp sub-assembly can now be re-installed, following backward all the above listed steps.

8- VOLTAGE AND FREQUENCY

The MAX L with electronic ballast can operate at 90-260V AC , 50 or 60 Hz.

9- INSTALLATION

MAX L may be either floor or ceiling mounted.

For floor mounting installations, the MAX L is supplied with four rubber mounting feet on the base.

For ceiling mounted installations, we recommend the use of appropriate clamps to fix the unit to the mounting surface.

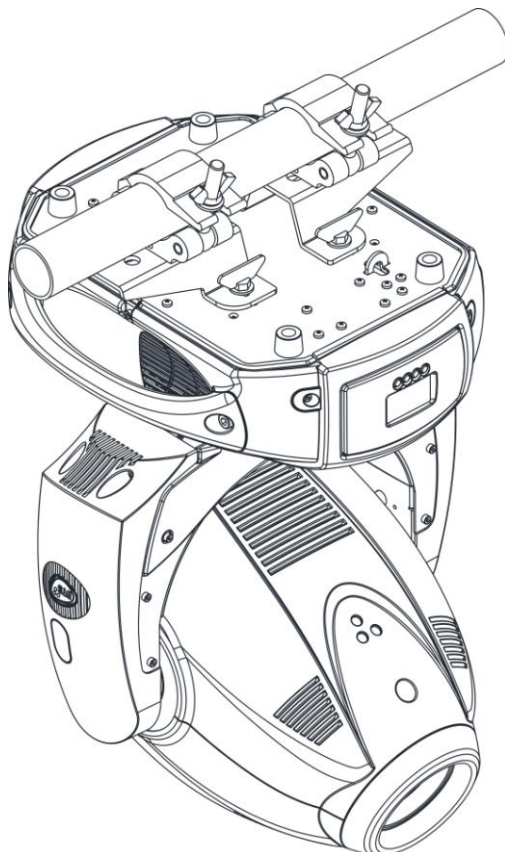
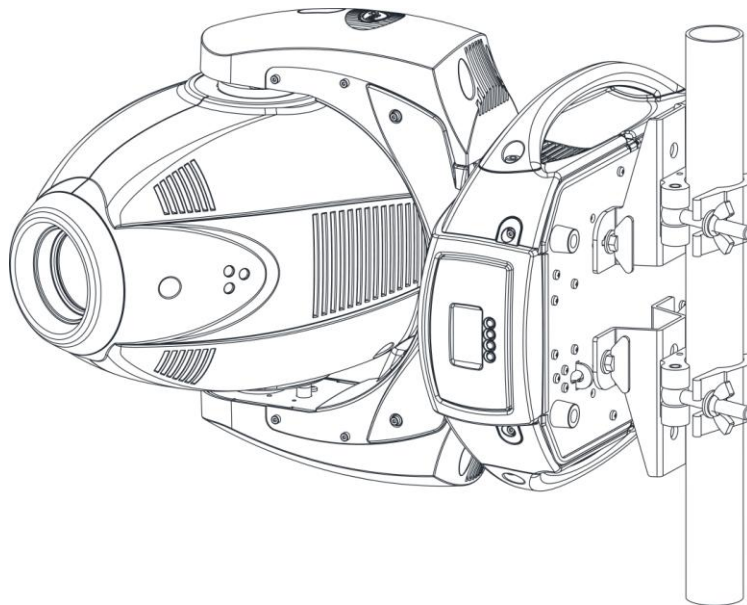

The supporting structure from which the unit is hung should be capable of bearing the weight of the unit, as should any clamps used to hang it. The structure should also be sufficiently rigid so as not to move or shake whilst the MAX L is moving.

Four 1/4 turn Fast Locks connections placed in the base of the unit allow to hang the MAX L by using the two omega clamps (provided in the box) in conjunction with fixing clamps for truss (fixing clamps are not included into the unit box).

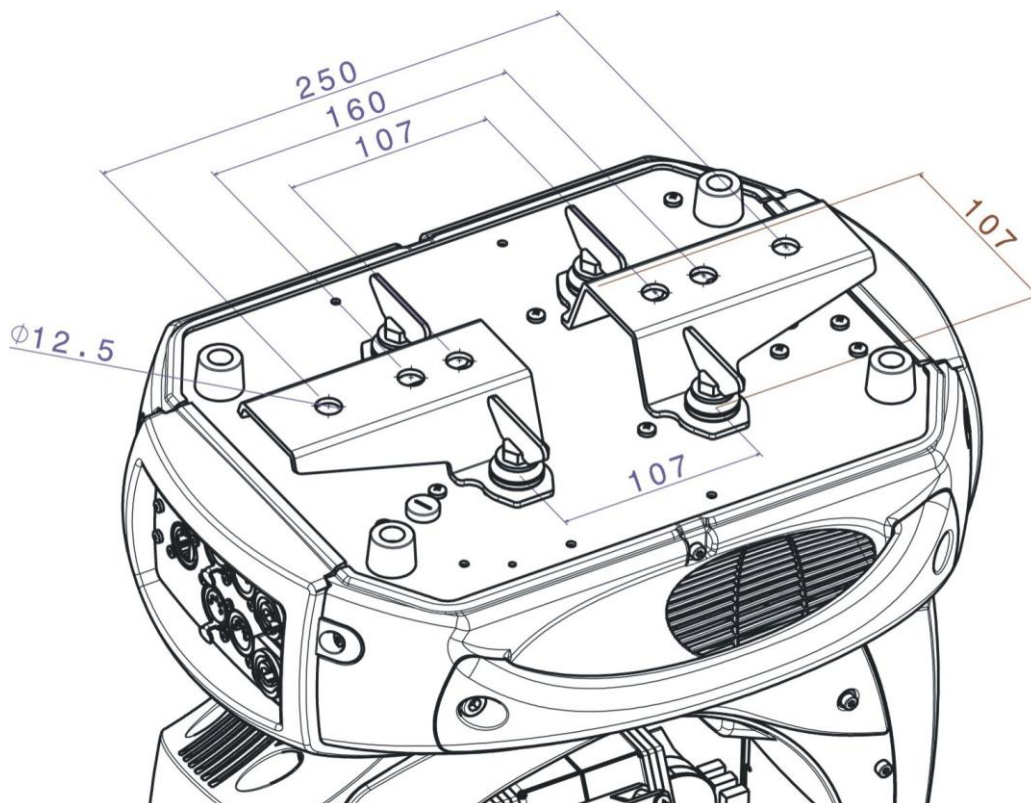
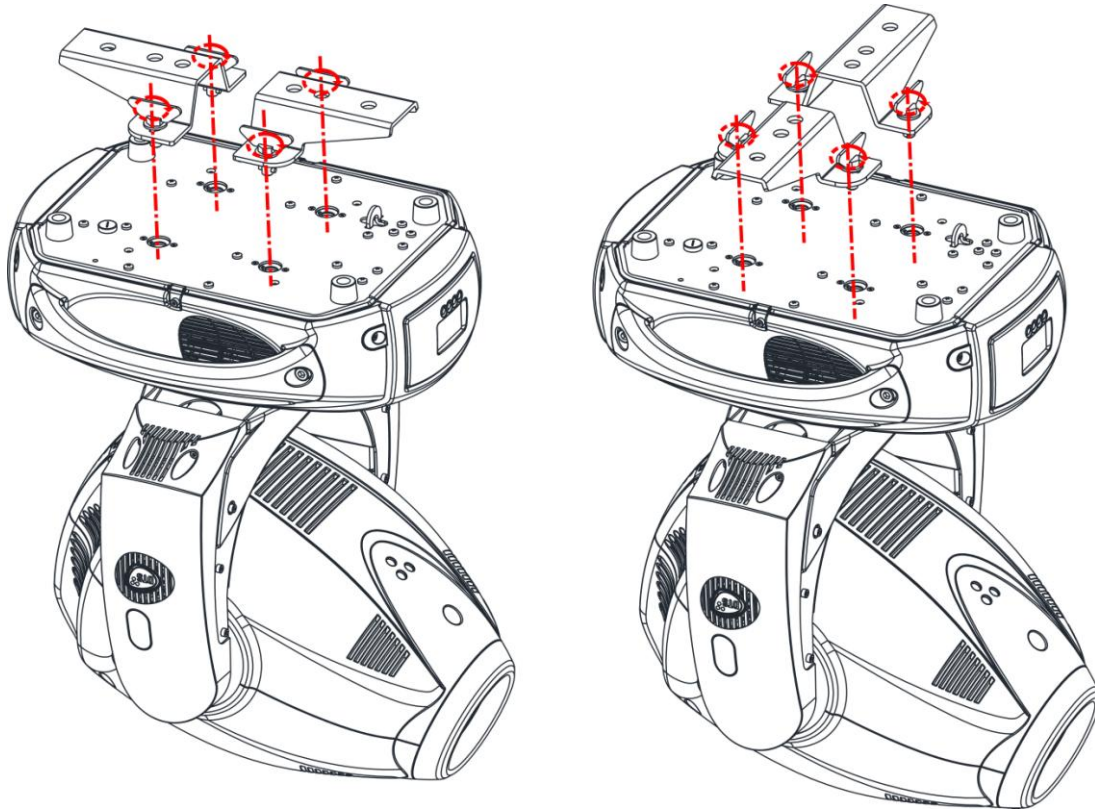

9.1- Safety cable



We recommend the use of a safety cable or chain connected to the MAX and to the suspension truss in order to avoid the fixture accidentally falling should the main fixing point fail.

Make sure that the iron cable or chain can bear the weight of the entire unit.

You may attach the safety chain/cord to the attachment point (A) located on the base of the fixture, as shown in the picture below.

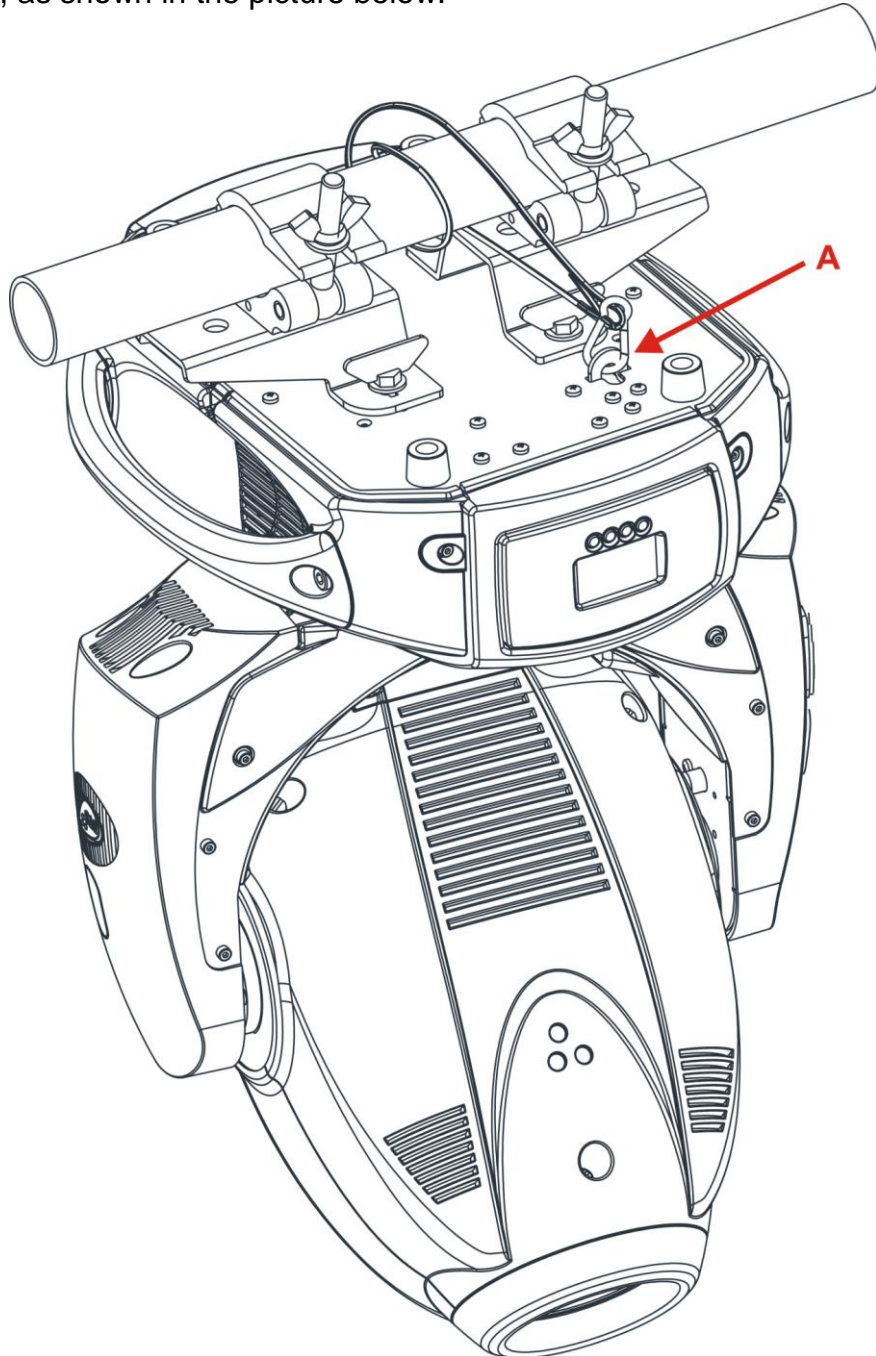

9.2 Protection against liquids

The projector contains electric and electronic components which should under no circumstances come into contact with oil, water or any other liquid.

The proper unit functioning would be compromised should this occur.

9.3- Movement

Pan 540° (2,5 sec.); Tilt 270° (1,5 sec.) .

Do not place any obstructions in the path of the projector's movement.



WARNING

Do not place any object in the path of the projector's movement

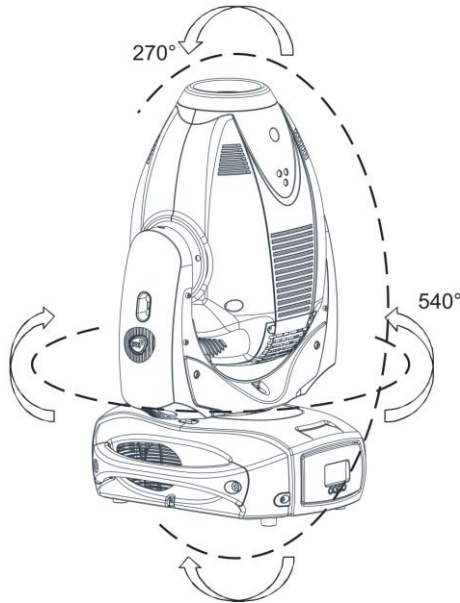

9.4- Risk of fire

Each fixture produces heat and must be installed in a well-ventilated place.

The unit is suitable for mounting on normally flammable surfaces greater than 200°C with some combustion time lag.



Minimum distance from the object being illuminated is 2 m. 2 m

9.5- Forced ventilation

You will note, on inspection, that the unit features various air inlets and cooling fans located on both the base and head of the fixture.

These should, under no circumstances, be blocked or obstructed whilst the projector is in operation. Doing so could cause the fixture to seriously overheat thereby compromising its proper operation.

9.6- Ambient temperature

The projector should never be installed in places that lack a constant air flow. The ambient temperature should not exceed 40°C.

10- MAINS CONNECTION

MAX L with electronic ballast operates at 90-260V AC 50/60 Hz.

Prior to connecting the unit to your mains supply, ensure that the model in your possession correctly matches the mains supply available.

For connection purposes, ensure that your plug is capable of supporting 2,5 amps at 230 V or 6 amps at 90 V each unit connected.

Strict adherence to regulatory norms is strongly recommended.

MAINS AC OUTPUT 90-260V AC 50/60 Hz (16A Max)

Max 6 MAX L units @ 230V

Max 3 MAX L units @ 120V

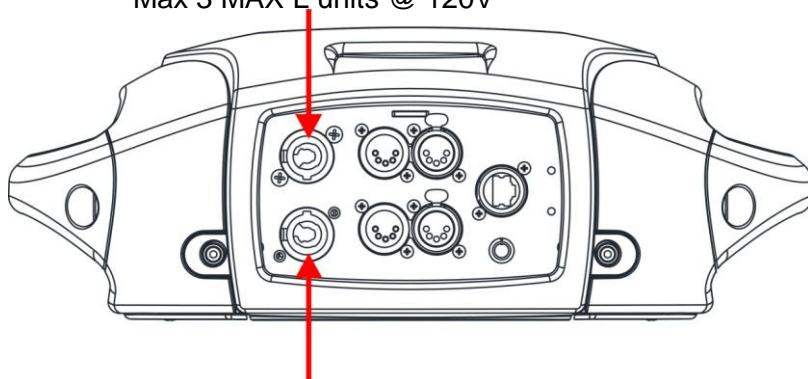

MAINS AC INPUT 90-260V AC 50/60 Hz

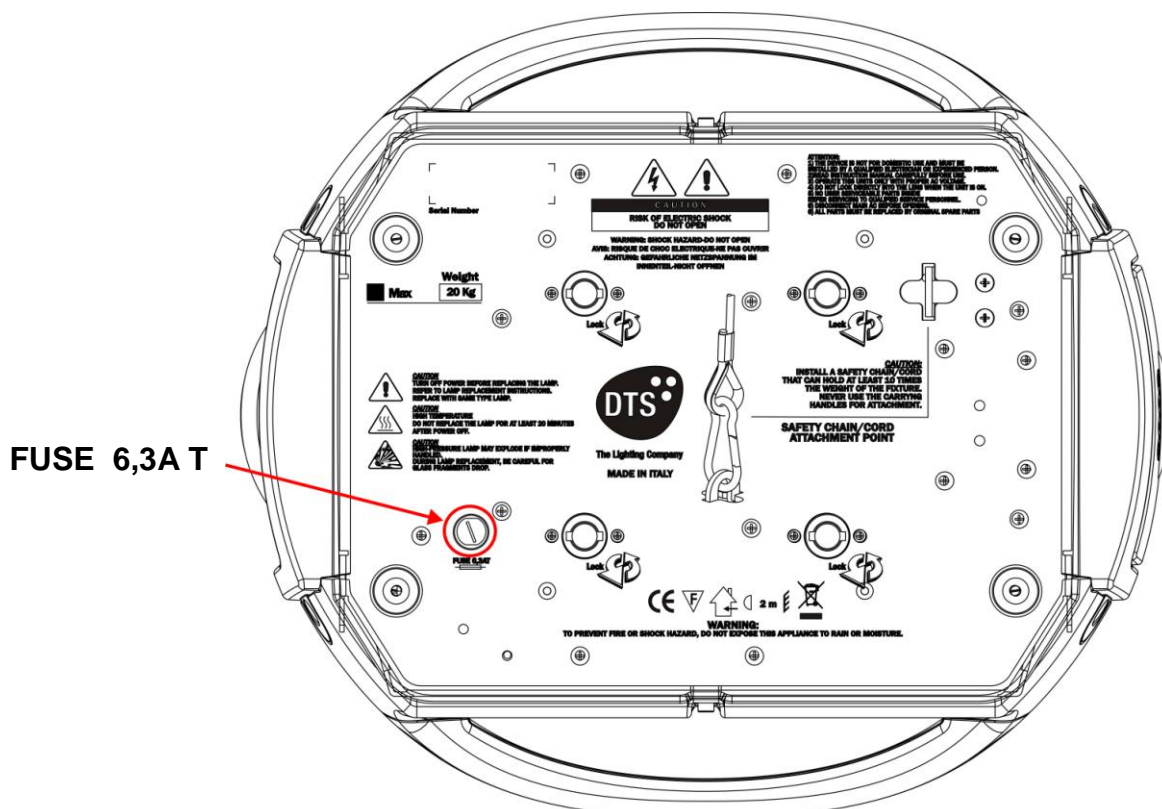

10.1- Protection



The use of a thermal magnetic circuit breaker is recommended for each MAX L. It is, moreover, recommended to protect the supply lines of the projectors by using appropriately sized residual current devices. Connection must be made to a power supply system fitted with efficient earthing (Class I appliance).

A good earth connection is essential for the correct operation of the projector.



11- DMX SIGNAL CONNECTION

The unit operates using the digital DMX 512 signal.

Connection between the mixer and the projector or between projectors must be carried out using a two pair screened \varnothing 0.5 mm cable and a XLR 5 or 3 pins connector.

Ensure that the conductors do not touch each other.

Do not connect the cable ground to the XLR chassy.

The plug housing must be isolated. Connect the mixer signal to the DMX IN projector plug and connect it to the next projector by connecting the DMX OUT plug on the first projector to the DMX IN plug of the second one.

This way, all the projectors are cascade connected.

NB. If the display showing the DMX address flashes, then one of the following errors has occurred:

- DMX signal not present
- DMX address not valid
- DMX reception problem

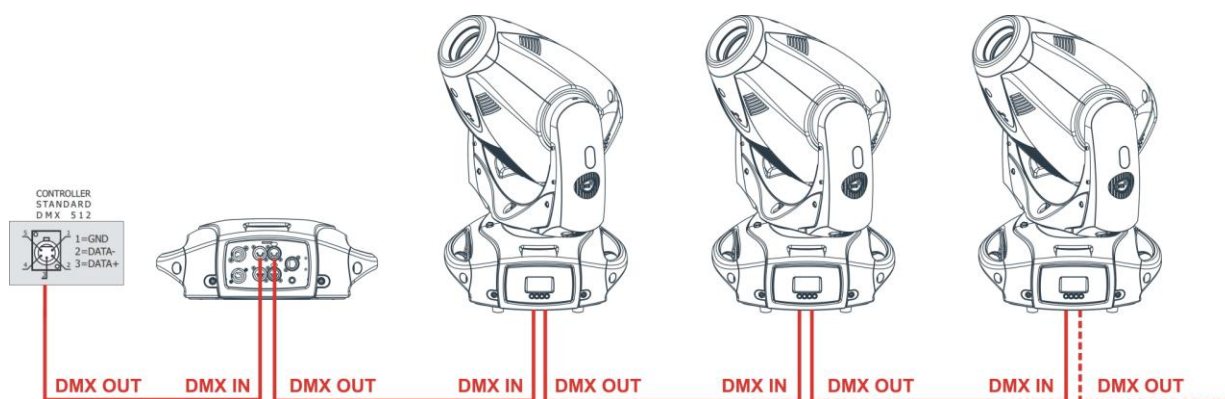

For Installations where long distance DMX cable connections are needed, we suggest to use a DMX terminator.

The DMX terminator is a male XLR 3-5 pins connector with a 120 ohm resistor between pin 2 and 3.

The DMX terminator must be plugged into the last unit (DMX out panel connector) of the DMX line.

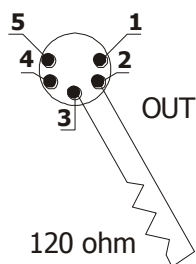

PLACE A 120 OHM RESISTOR BETWEEN PIN 2 AND 3 OF A MALE XRL CONNECTOR AND PLUG IT INTO THE DMX OUT PANEL CONNECTOR OF THE LAST UNIT CONNECTED TO THE DMX LINE

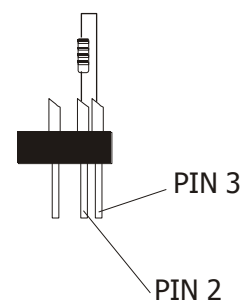

11.1-DMX Addresses

MAX L can be used in 2 different DMX modes: 24 or 18 DMX control channels. Here below is described the DMX channels addressing for the controller when MAX L is set to 24 (Default) and 18 DMX control channels:

24 channels mode (Default)

Projector 1	A001	
Projector 2	A025	If you want to select the next projector, just add "24"
Projector 3	A049	
.....	A....	
projector 6	A121	

18 channels mode

Projector 1	A001	
Projector 2	A019	If you want to select the next projector, just add "18"
Projector 3	A037	
.....	A....	
projector 6	A091	

11.2-Selecting the DMX address

- 1) Press the UP-DOWN key until you reach the required DMX channel. The numbers on the display will start to flash (but the new DMX address hasn't yet been set).
- 2) Press ENTER to confirm your selection. The numbers on the display will stop flashing and the projector is now setted to the new DMX address.

TRICKS:

If you keep pushed the UP or DOWN keys, the channels are calculated more quickly and you get a faster selection.

12- FIRMWARE UPDATING

To update the software version of the MAX L you need:

- "D.T.S. Firmware Upgrade Utility" program installed on the PC
- D.T.S. RED BOX interface (D.T.S. Code: 03.LA.008)
- USB-DMX Driver for the D.T.S. RED BOX interface
- Latest firmware release available for MAX L unit

Updating the software version.

Please follow the procedure below to perform the update:

1. Install the D.T.S. RED BOX USB-DMX driver on the PC you will use to update the unit software.
2. Connect the D.T.S. RED BOX interface to the PC by using a USB cable.
3. Connect the D.T.S. RED BOX interface to the fixture by using a DMX cable.
4. Send the new software version into the unit by using "D.T.S Firmware Upgrade Utility" program.

13- DISPLAY FUNCTIONS

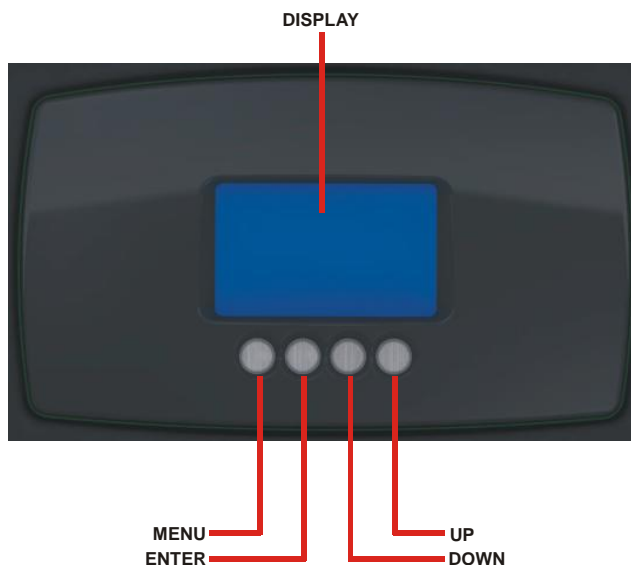





















DISPLAY FUNCTIONS

The MAX L display panel shows all the available functions. Using these functions, it is possible to change some of the parameters and add some functions. Changing the D.T.S. setting can vary the functions of the unit so that it does not respond to the DMX 512 used to control it. Carefully follow the instructions below before carrying out any variations or selections.

NOTE: the symbol  shows which key has to be pushed to obtain the desired function.

Software Version: 28.18

  Pan Direction PAN DIRECTION This menu allows to set the Pan movement Normal or Reverse	 	<div style="background-color: #0070C0; color: white; padding: 5px; text-align: center;"> PAN DIRECTION </div> <div style="background-color: #0070C0; color: white; padding: 20px; text-align: center; font-size: 24px; font-weight: bold;"> NORMAL </div> <div style="background-color: #0070C0; color: white; padding: 5px; text-align: center; font-size: 12px;"> MENU ENTER DOWN UP </div>	Pan movement Normal or Reverse Default = Normal 
  Tilt Direction TILT DIRECTION This menu allows to set the Tilt movement Normal or Reverse	 	<div style="background-color: #0070C0; color: white; padding: 5px; text-align: center;"> TILT DIRECTION </div> <div style="background-color: #0070C0; color: white; padding: 20px; text-align: center; font-size: 24px; font-weight: bold;"> NORMAL </div> <div style="background-color: #0070C0; color: white; padding: 5px; text-align: center; font-size: 12px;"> MENU ENTER DOWN UP </div>	Tilt movement Normal or Reverse Default = Normal 
  Pan Speed PAN SPEED Pan Speed control (1-4)	 	<div style="background-color: #0070C0; color: white; padding: 5px; text-align: center;"> PAN SPEED </div> <div style="background-color: #0070C0; color: white; padding: 20px; text-align: center; font-size: 24px; font-weight: bold;"> 4 </div> <div style="background-color: #0070C0; color: white; padding: 5px; text-align: center; font-size: 12px;"> MENU ENTER DOWN UP </div>	Pan Speed control (1-4) Default = 4 
  Tilt Speed TILT SPEED Tilt Speed control (1-4)	 	<div style="background-color: #0070C0; color: white; padding: 5px; text-align: center;"> TILT SPEED </div> <div style="background-color: #0070C0; color: white; padding: 20px; text-align: center; font-size: 24px; font-weight: bold;"> 4 </div> <div style="background-color: #0070C0; color: white; padding: 5px; text-align: center; font-size: 12px;"> MENU ENTER DOWN UP </div>	Tilt Speed control (1-4) Default = 4 

13- DISPLAY FUNCTIONS



Display



DISPLAY FLIP / STAND BY / CONTRAST

Display Flip:
Reverses display's reading depending on the mounting position (on the ground or suspended).

Display Standby:
To turn off the display (after 5 seconds) or leave it always on.

Display Contrast:
Display contrast regulation (1-40)

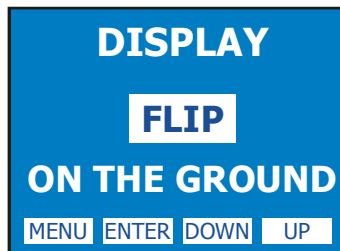

Display Flip
ON THE GROUND (Default)
SUSPENDED

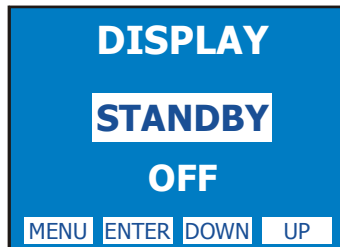

Display Standby
OFF = Display Standby disabled (Default)
ON = Display goes OFF after 5 seconds

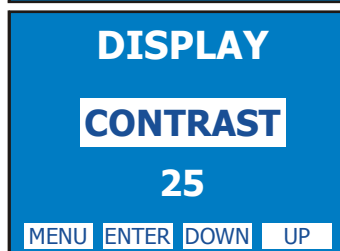

Display Contrast
1-40 (Default = 25)



DMX Mode



DMX MODE
To select DMX mode:
24 channels (Default) or 18 channels

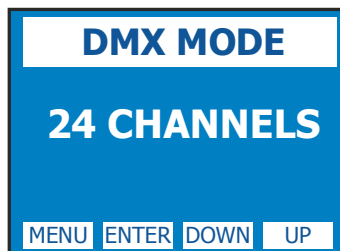

DMX Mode
24 channels (Default)
18 channels



Lamp



LAMP
Lamp always ON, Lamp always OFF, lamp ON-OFF selectable via DMX and lamp life time reset

ADJUST
To adjust the lamp with no mixer connected. It's possible to set the parameters for PAN-TILT, FOCUS-FOCUS FINE and ZOOM.

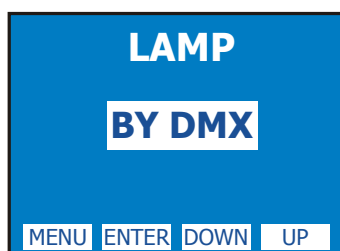

BY DMX = Lamp ON / OFF via DMX (Default)
ALWAYS ON = Forced ON
ALWAYS OFF = Forced OFF
RESET COUNTER = Lamp life time reset

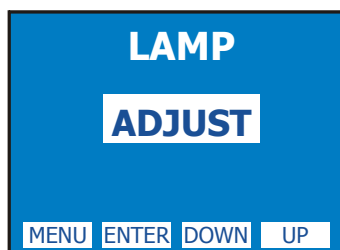

LAMP ADJUST = To adjust the lamp with no mixer connected. It's possible to set the parameters for PAN-TILT, FOCUS-FOCUS FINE and ZOOM



Reset



RESET
Reset via DMX ENABLED / DISABLED and unit motors reset

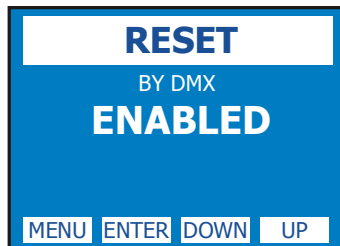

ENABLED = Reset via DMX enabled (Default)
DISABLED = Reset via DMX disabled
NOW = Unit motors reset



13- DISPLAY FUNCTIONS



Fans Setting



FANS SETTING

LIVE-TOUR mode (Default) or STUDIO mode



LIVE-TOUR mode =
High fans speed: the lamp
always works at maximum
power (Default)

STUDIO mode =
Low fans speed for a very
low noise operation: the
lamp may be dimmed in
particular circumstances



Gobo Rotation



GOBO ROTATION

Gobo rotation during gobo scrolling
for rotating gobo wheel

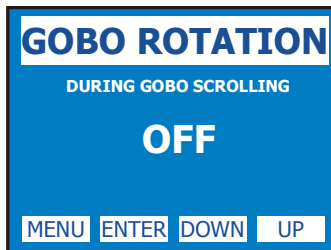

OFF = Default
ON



Gobo 9



GOBO 9

To use the gobo 9 of the rotating gobo
wheel with the gobo Open-Studio (Default)
or with the user gobo.

This parameter lets you have the correct
focusing for each situation.



OPEN-STUDIO = To have
the gobo Open-Studio
focusing (Default)
USER GOBO = To have the
user gobo focusing

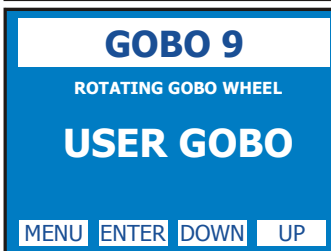

Gobo 10



GOBO 10

To use the gobo 10 of the fixed gobo
wheel with the Frost glass gobo (Default)
or with the user gobo.

This parameter lets you have the correct
focusing for each situation.



FROST = To have
the Frost glass gobo
focusing (Default)
USER GOBO = To have the
user gobo focusing



13- DISPLAY FUNCTIONS



Focus



FOCUS FINE
Range Ctrl 5% or 16 Bit Ctrl (Default)
To select the Focus Fine change on the Focus channel.

AUTOFOCUS
Automatic focusing

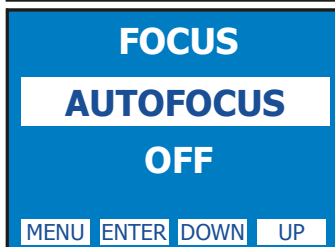

FOCUS FINE
RANGE CTRL 5% = To have a 5% Focus Fine change on the Focus channel.
16 BIT CTRL = To have a Focus Fine function same as the real 16 bit Focus Fine channel (Default).

AUTOFOCUS
ON
OFF = Default



Zoom



ZOOM Range & Speed
This menu' allows to select the Zoom Range & Speed of the MAX L unit (NORMAL as default).

Zoom Range & Speed can also be set "SAME AS MAX" in order to keep compatibility between the 2 units.

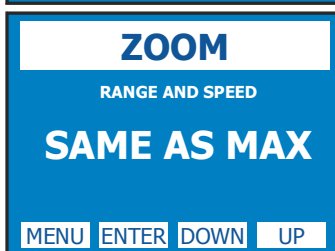
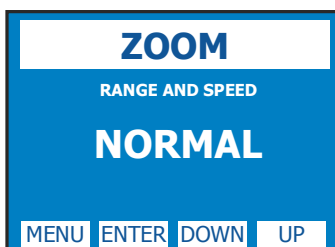

ZOOM
NORMAL: Standard Zoom Range & Speed (Default)

SAME AS MAX: to have same Zoom Range & Speed as MAX unit.



Black-out



BLACK-OUT
Fixed gobo wheel inserted between gobo 1 and gobo 2 when Dimmer is closed. By activating this function, it will be possible to reduce substantially any visible light reflection coming out from the front lens.

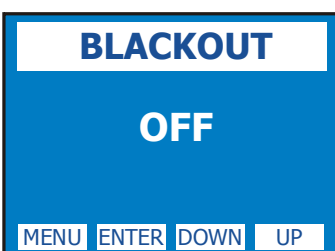

OFF = Black-out disabled (Default)
SNAP = Immediate Black-out
DELAY 1-5 SEC = Black-out enabled after 1, 2, 3, 4 or 5 seconds from Dimmer closed



Wireless



WIRELESS
Wireless DMX enabled / disabled.

(Wireless module on request)

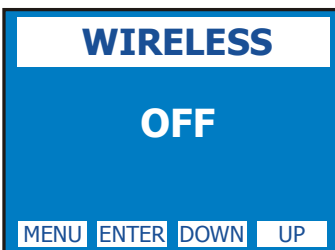

ON = Enabled
OFF = Disabled (Default)
UNLINK = Log out

(Wireless module on request)



System Info



SYSTEM INFO
Lamp life time, lamp strikes, unit life time, 9 motors card software version, Pan&Tilt card software version and unit model

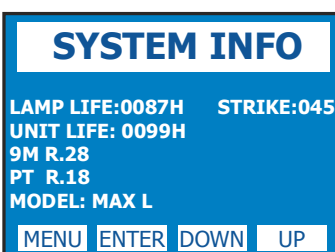

SYSTEM INFO
Lamp life time, lamp strikes, unit life time, 9 motors card software version, Pan&Tilt card software version and unit model



13- DISPLAY FUNCTIONS



Reserved



RESERVED
(Code = 100)
Pan lock-Tilt lock
Pan free-Tilt free
Lock Detector
Reboot
Exit To Main

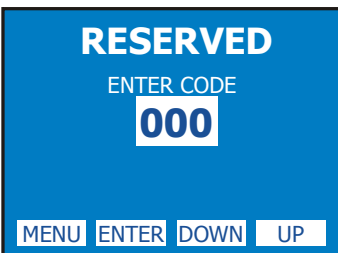

Pan Lock = Lock the Pan to the desired value
Tilt Lock = Lock the Tilt to the desired value
Pan Free = Remove power to Pan motor
Tilt Free = Remove power to Tilt motor



Lock Detector OFF = Default
Lock Detector ON: This function let the user to activate the Lock detector on Pan and Tilt. When Lock detector is set to ON, the unit start the Pan&Tilt motors reset normally, but if for any reason there is something blocking the movement for Pan&Tilt motors during the initial reset (example unit into the fly case and power connected), it automatically will stop to reset Pan&Tilt motors after 5 seconds from the startup and a warning message (Pan Locked-Tilt locked) will appear on unit display .

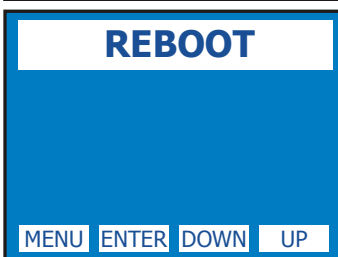
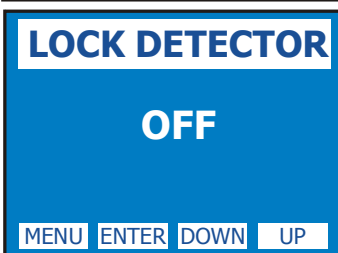

Reboot = Unit Reboot without needing of turning OFF the unit

Exit To Main = Exit from Reserved menu



R. Gobo Speed



ROTATING GOBO SPEED
To decrease the rotating gobo wheel speed from fastest (default) to fast



Fastest speed (Default) or Fast speed



Default



DEFAULT
To restore main settings

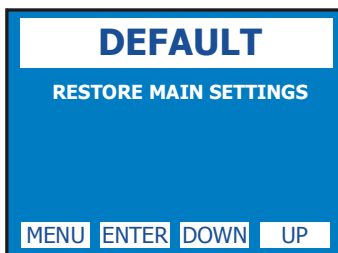

Default
To restore main settings

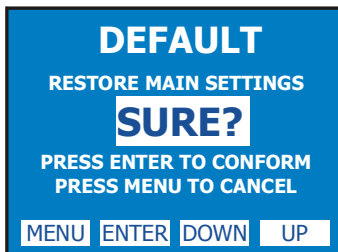

14- ERROR MESSAGES

<p>ERROR</p> <p>PAN</p> <p>MENU ENTER DOWN UP</p>	<p>ERROR</p> <p>TILT</p> <p>MENU ENTER DOWN UP</p>	<p>PAN</p> <p>LOCKED</p> <p>MENU ENTER DOWN UP</p>	<p>TILT</p> <p>LOCKED</p> <p>MENU ENTER DOWN UP</p>
---	--	--	---

PAN REPOSITIONING
ENCODER ERROR

TILT REPOSITIONING
ENCODER ERROR

PAN LOCKED

TILT LOCKED

<p>ERROR</p> <p>BUS 9 MOTORS</p> <p>MENU ENTER DOWN UP</p>	<p>ERROR</p> <p>GOBO</p> <p>MENU ENTER DOWN UP</p>	<p>ERROR</p> <p>GOBO INDEX</p> <p>MENU ENTER DOWN UP</p>	<p>ERROR</p> <p>FIXED GOBO</p> <p>MENU ENTER DOWN UP</p>
--	--	--	--

COMMUNICATION
PROBLEM BETWEEN
9 MOTORS CARD AND
PAN&TILT CARD

ROTATING GOBO
WHEEL POSITION
ERROR

GOBOS POSITION
ERROR

FIXED GOBO WHEEL
POSITION ERROR

<p>ERROR</p> <p>COLOUR WHEEL</p> <p>MENU ENTER DOWN UP</p>	<p>ERROR</p> <p>PRISM</p> <p>MENU ENTER DOWN UP</p>	<p>ERROR</p> <p>FOCUS</p> <p>MENU ENTER DOWN UP</p>	<p>ERROR</p> <p>ZOOM</p> <p>MENU ENTER DOWN UP</p>
--	---	---	--

COLOUR WHEEL
POSITION ERROR

PRISM POSITION
ERROR

FOCUS POSITION
ERROR

ZOOM POSITION
ERROR

<p>ERROR</p> <p>DMX ADDRESS</p> <p>MENU ENTER DOWN UP</p>	<p>ERROR</p> <p>BUS AUX FANS CARD</p> <p>MENU ENTER DOWN UP</p>
---	---

DMX ADDRESS
ERROR

COMMUNICATION
PROBLEM BETWEEN
FANS CONTROL CARD
AND PAN&TILT CARD

15- HIDDEN MENU (only for technical personnel)

To operate this menu:

- Connect the projector to the DMX controller (DMX SIGNAL MUST BE CORRECTLY RECEIVED)
- Reset the MAX L (reset from the MENU, not from the DMX controller).
- While reset is running, press the MENU and ENTER keys at the same time.

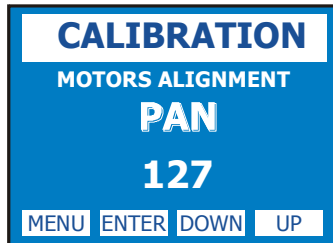

ELECTRONIC
CALIBRATION OF
THE MOTORS

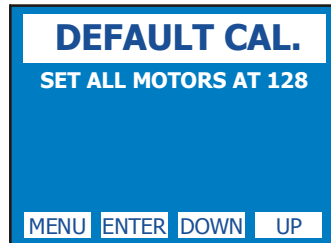

RESET ALL SETTINGS
TO VALUE 128

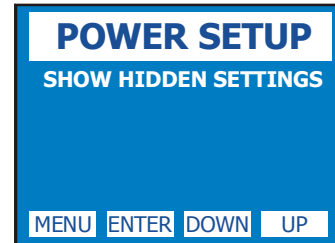

FANS / POWER SETTINGS
MENU



EXIT FROM HIDDEN MENU

15.1 Calibration mode

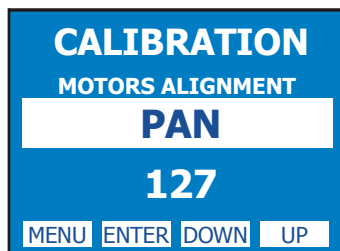

PAN ALIGNMENT
To align Pan position

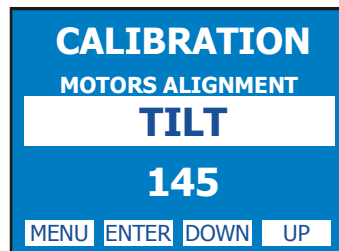

TILT ALIGNMENT
To align Tilt position

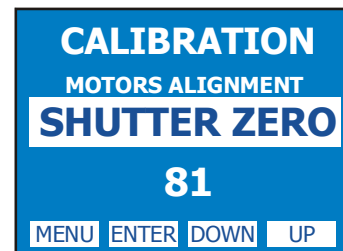

SHUTTER ZERO ALIGNMENT
Shutter zero position setting



SHUTTER PATH ALIGNMENT
Shutter excursion setting



COLOUR WHEEL ALIGNMENT
To align Colour wheel



GOBO 0-8 ALIGNMENT
To align Rotating gobo wheel
from gobo 0 to gobo 8

15.1 Calibration mode

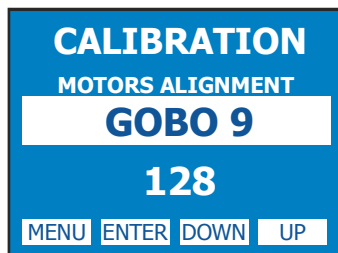

GOBO 9 ALIGNMENT
To align Gobo 9 of the rotating gobo wheel



GOBO WHEEL INDEX ALIGNMENT
To align Gobo wheel index

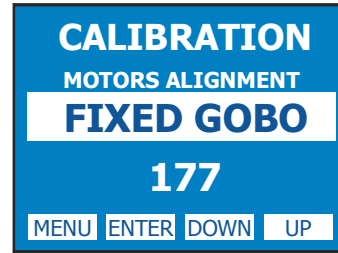

FIXED GOBO WHEEL ALIGNMENT
To align Fixed gobo wheel



PRISM ZERO ALIGNMENT
Prism Zero position setting

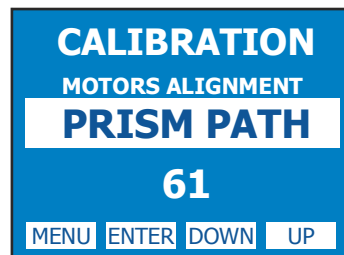

PRISM PATH ALIGNMENT
Prism excursion setting

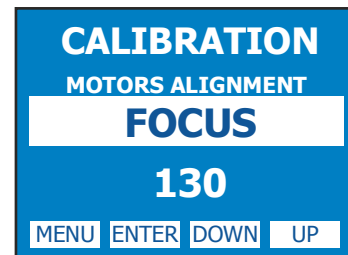

FOCUS ALIGNMENT
Focus position setting



ZOOM ZERO ALIGNMENT
Zoom Zero position setting



ZOOM PATH ALIGNMENT
Zoom excursion setting



FOCUS ROT. GOBO 0-9
Rotating gobos focusing from gobo 0 to gobo 9

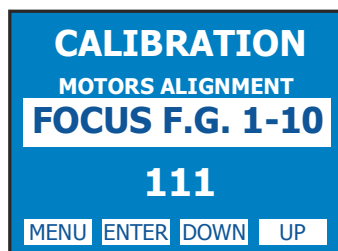

FOCUS FIX. GOBO 1-10
Fixed gobos focusing from gobo 1 to gobo 10

16- PAN SPEED & TILT SPEED

You can set the PAN and TILT motors at high speed on your MAX.
 Press menu until you see PAN SPEED / TILT SPEED.
 Press ENTER and select a speed with UP-DOWN (there are 4 speeds).
 Confirm by pressing ENTER.

17- OPENING THE PROJECTOR HOUSING

It is possible to inspect the inside of the projector by removing the cover as indicated below.

ATTENTION
REMOVE MAINS POWER PRIOR TO ACCESSING THE PROJECTOR'S INTERNAL COMPONENTS.



1) Loosen the 3 “¼ turn” screws which fix the head covers on both sides (picture 1) .

2) Once loosened the screws, simply lift the covers to access the internal components (picture 2).

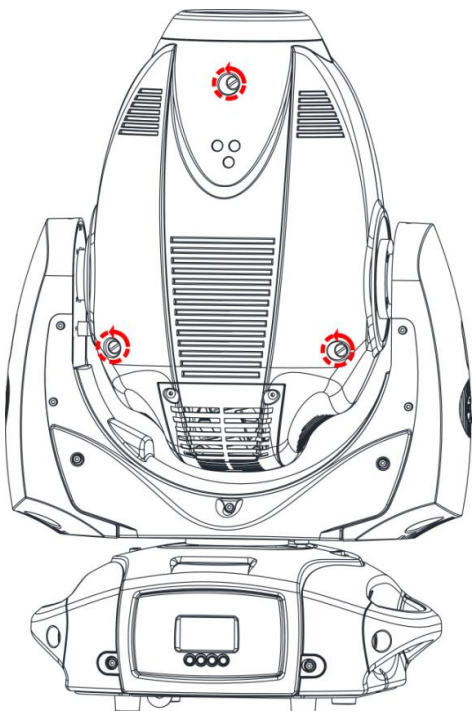

PICTURE 1

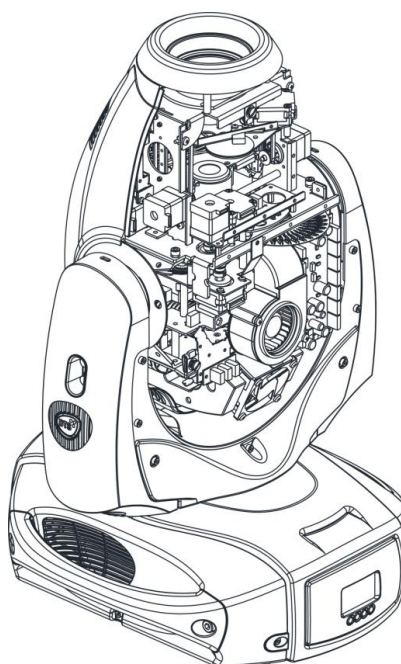

PICTURE 2

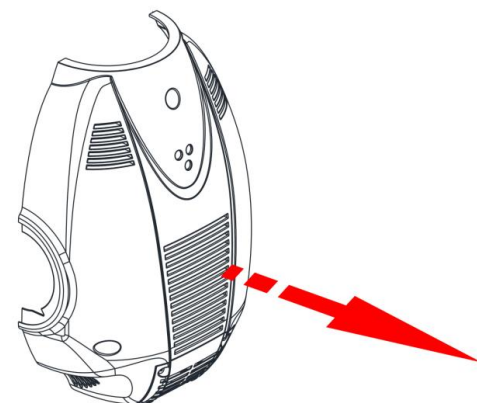

18- PERIODIC CLEANING

18.1- Lenses and reflectors

Even a fine layer of dust can reduce the luminous output substantially.

Regularly clean all lenses and the reflector using a soft cotton cloth, dampened with a specialist lens cleaning solution.

18.2- Fans and air passages

The fans and air passages must be cleaned approximately every 6 weeks.

This periodic cleaning will depend of course, on the conditions in which the projector is operating.

Suitable instruments for performing this type of maintenance are a brush and a common vacuum cleaner or an air compressor.

If necessary, clean the fans and air passages more frequently.

19- PERIODIC CONTROLS

Attention



Disconnect mains power prior to removing the projector housing.

Lamp



The lamp should be replaced if there is any visible damage or deformation due to heat. This will help to avoid the danger of the lamp exploding.

MAX L lamp lifespan is about 1500 hours, then it is necessary to replace it.

Mechanical parts

Periodically check all mechanical parts, gears, guides, belts, etc. for wear and tear, replacing them if necessary.

Periodically check the lubrication of all components, particularly the parts subject to high temperatures.

If necessary, lubricate with suitable lubricant, available from your D.T.S. distributor.

Check the tension of the belts and adjust it if necessary.

Electrical components



Check all electrical components for correct earthing and proper connection of all connectors, refastening if necessary.

Fuse replacement

Locate the fuse, which protects the lamp and electronics, in the base of the MAX L.

Using a multimeter, test the condition of the fuse, replacing it with one of equivalent type (6,3AT) if necessary.

20- DMX PROTOCOL**24 CHANNELS MODE (Default)**

1	PAN msb
2	PAN lsb
3	TILT msb
4	TILT lsb
5	SPEED MOVEMENT
6	PAN FAR
7	DIMMER
8	SHUTTER
9	COLOUR
10	COLOUR MODE
11	GOBO
12	GOBO MODE
13	GOBO ROTATION/INDEX
14	GOBO INDEX FINE
15	GOBO SHAKE
16	FIXED GOBO
17	FIXED GOBO SHAKE
18	FROST
19	PRISM
20	PRISM ROTATION
21	FOCUS
22	FOCUS FINE
23	ZOOM
24	RESET+LAMP

DMX CHANNEL	1	Parameter: PAN msb
DMX CHANNEL	2	Parameter: PAN lsb

DMX CHANNEL	3	Parameter: TILT msb
DMX CHANNEL	4	Parameter: TILT lsb

DMX CHANNEL	5	Parameter: SPEED MOVEMENT
DMX value	Function	
000-010	Standard	
011-025	Fast movement	
026-127	Vector mode from fast to slow	
128-247	Variable time reaction to dmx signal (fast to slow)	
248-255	Silent movement	

DMX CHANNEL	6	Parameter: PAN FAR
DMX value	Function	
000-010	Position mode 540° (standard path)	
011-020	Position mode 360° (1 turn)	
021-030	Position mode 720° (2 turns)	
031-040	Position mode 1080° (3 turns)	
041-050	Position mode 1440° (4 turns)	
051-060	Position mode 1800° (5 turns)	
061-070	Position mode 2160° (6 turns)	
071-080	Position mode 2520° (7 turns)	
081-090	Position mode 2880° (8 turns)	
091-100	Position mode 3240° (9 turns)	
101-110	Position mode 3600° (10 turns)	
111-120	Position mode 360° smart path	
121-182	Forward spin rotation speed from max to min	
183-193	Stop	
194-255	Reverse spin rotation speed from min to max	

DMX CHANNEL	7	Parameter: DIMMER
DMX value	Function	
000-007	Black-out	
008-255	Proportional dimmer	

DMX CHANNEL	8	Parameter: SHUTTER
DMX value	Function	
000-019	Black-out	
020-039	Open	
040-059	Black-out	
060-079	Strobe random speed	
080-089	Strobe speed 1 (0.86 flash/sec)	
090-099	Strobe speed 2 (1.40 flash/sec)	
100-109	Strobe speed 3 (3.78 flash/sec)	
110-119	Strobe speed 4 (5.00 flash/sec)	
120-129	Strobe speed 5 (6.75 flash/sec)	
130-139	Strobe speed 6 (10.00 flash/sec)	
140-149	Flash open speed 1	
150-159	Flash open speed 2	
160-169	Flash open speed 3	
170-179	Flash open speed 4	
180-189	Flash closed speed 1	
190-199	Flash closed speed 2	
200-209	Flash closed speed 3	
210-219	Flash closed speed 4	
220-227	Colours/Gobo in black-out	
228-233	Pan/Tilt in black-out	
234-255	Open	

DMX CHANNEL	9	Parameter: COLOUR
-------------	---	-------------------

FULL COLOUR (CH9 = 0-63)

DMX value	Function
000-013	Colour 1
014-027	Colour 2
028-041	Colour 3
042-055	Colour 4
056-069	Colour 5
070-083	Colour 6
084-097	Colour 7
098-111	Colour 8
112-125	Colour 9
126-139	Colour 10
140-153	Colour 11
154-167	Colour 12
168-181	Colour 13
182-195	Colour 14
196-209	Colour 15
210-223	Colour 16
224-237	Colour 17
238-255	Colour 18

HALF COLOUR (CH9 = 64-127)

DMX value	Function
000-012	Colour 1
013-025	Colour 1-2
026-038	Colour 2-3
039-051	Colour 3-4
052-064	Colour 4-5
065-077	Colour 5-6
078-090	Colour 6-7
091-103	Colour 7-8
104-116	Colour 8-9
117-129	Colour 9-10
130-142	Colour 10-11
143-155	Colour 11-12
156-168	Colour 12-13
169-181	Colour 13-14
182-194	Colour 14-15
195-207	Colour 15-16
208-220	Colour 16-17
221-233	Colour 17-18
234-255	Colour 18-1

PROPORTIONAL COLOUR (CH9 = 128-191)

DMX value	Function
000-010	No colour
011-255	Proportional colour

RAINBOW (CH9 = 192-255)

DMX value	Function
000-009	No colour
010-127	Right rotation speed from max to min
128-137	Stop
138-255	Left rotation speed from min to max

DMX CHANNEL	10	Parameter: COLOUR MODE
-------------	----	------------------------

DMX value	Function
000-063	Full colour
064-127	Half colour
128-191	Proportional colour
192-255	Rainbow

DMX CHANNEL	11	Parameter: GOBO
DMX value	Function	
000-020	Open	
021-041	Gobo 1	
042-062	Gobo 2	
063-083	Gobo 3	
084-104	Gobo 4	
105-125	Gobo 5	
126-146	Gobo 6	
147-167	Gobo 7	
168-188	Gobo 8	
189-207	Gobo 9	
208-213	Speed rotation 1 min	
214-219	Speed rotation 2	
220-225	Speed rotation 3	
226-231	Speed rotation 4	
232-237	Speed rotation 5	
238-243	Speed rotation 6	
244-249	Speed rotation 7	
250-255	Speed rotation 8 max	

DMX CHANNEL	12	Parameter: GOBO MODE
DMX value	Function	
000-127	Gobo rotation mode	
128-255	Gobo index mode	

DMX CHANNEL	13	Parameter: GOBO ROTATION/INDEX
GOBO MODE ROTATION		
DMX value	Function	
000-009	Stop	
010-127	Left rotation (max to min)	
128-137	Stop	
138-255	Right rotation (min to max)	

GOBO MODE INDEX		
DMX value	Function	
000-255	Gobo index coarse	

DMX CHANNEL	14	Parameter: GOBO INDEX FINE
DMX value	Function	
000-255	Gobo index fine	

DMX CHANNEL	15	Parameter: GOBO SHAKE
DMX value	Function	
000-009	Stop	
010-022	Gobo shake R-L speed 1	
023-035	Gobo shake R-L speed 2	
036-048	Gobo shake R-L speed 3	
049-061	Gobo shake R-L speed 4	
062-074	Gobo shake R-L speed 5	
075-087	Gobo shake R-L speed 6	
088-100	Gobo shake R-L speed 7	
101-113	Gobo shake R-L speed 8	
114-126	Gobo shake R-L speed 9	
127-138	Stop	
139-151	Gobo shake L-R speed 1	
152-164	Gobo shake L-R speed 2	
165-177	Gobo shake L-R speed 3	
178-190	Gobo shake L-R speed 4	
191-203	Gobo shake L-R speed 5	
204-216	Gobo shake L-R speed 6	
217-229	Gobo shake L-R speed 7	
230-242	Gobo shake L-R speed 8	
234-255	Gobo shake L-R speed 9	

DMX CHANNEL	16	Parameter: FIXED GOBO
DMX value	Function	
000-018	Open	
019-037	Gobo 1	
038-056	Gobo 2	
057-075	Gobo 3	
076-094	Gobo 4	
095-113	Gobo 5	
114-132	Gobo 6	
133-151	Gobo 7	
152-170	Gobo 8	
171-189	Gobo 9	
190-207	Gobo 10	
208-213	Speed rotation 1 min	
214-219	Speed rotation 2	
220-225	Speed rotation 3	
226-231	Speed rotation 4	
232-237	Speed rotation 5	
238-243	Speed rotation 6	
244-255	Speed rotation 7 max	

DMX CHANNEL	17	Parameter: FIXED GOBO SHAKE
DMX value	Function	
000-009	Stop	
010-022	Gobo shake R-L speed 1	
023-035	Gobo shake R-L speed 2	
036-048	Gobo shake R-L speed 3	
049-061	Gobo shake R-L speed 4	
062-074	Gobo shake R-L speed 5	
075-087	Gobo shake R-L speed 6	
088-100	Gobo shake R-L speed 7	
101-113	Gobo shake R-L speed 8	
114-126	Gobo shake R-L speed 9	
127-138	Stop	
139-151	Gobo shake L-R speed 1	
152-164	Gobo shake L-R speed 2	
165-177	Gobo shake L-R speed 3	
178-190	Gobo shake L-R speed 4	
191-203	Gobo shake L-R speed 5	
204-216	Gobo shake L-R speed 6	
217-229	Gobo shake L-R speed 7	
230-242	Gobo shake L-R speed 8	
234-255	Gobo shake L-R speed 9	

DMX CHANNEL	18	Parameter: FROST
DMX value	Function	
000-127	No effect	
128-255	Frost inserted	

DMX CHANNEL	19	Parameter: PRISM
DMX value	Function	
000-127	No effect	
128-255	Prism inserted	

DMX CHANNEL	20	Parameter: PRISM ROTATION
DMX value	Function	
000-009	Stop	
010-127	Left rotation from fast to slow	
128-137	Stop	
138-255	Right rotation from slow to fast	

DMX CHANNEL	21	Parameter: FOCUS
DMX value	Function	
000-255	Linear focus (0-95)%	

DMX CHANNEL	22	Parameter: FOCUS FINE
DMX value	Function	
000-255	Linear focus (95-100)%	

DMX CHANNEL	23	Parameter: ZOOM
DMX value	Function	
000-255	Linear zoom	

DMX CHANNEL	24	Parameter: RESET + LAMP
DMX value	Function	
000-009	No effect	
010-060	Lamp OFF (3 sec)	
061-129	No effect	
130-179	Lamp ON (3 sec)	
180-200	No effect	
201-239	Internal motor reset	
240-255	Total reset	

20- DMX PROTOCOL**18 CHANNELS MODE**

- 1 PAN msb**
- 2 PAN lsb**
- 3 TILT msb**
- 4 TILT lsb**
- 5 SPEED MOVEMENT**
- 6 PAN FAR**
- 7 DIMMER**
- 8 SHUTTER**
- 9 COLOUR**
- 10 GOBO**
- 11 GOBO ROTATION/INDEX**
- 12 FIXED GOBO**
- 13 FROST**
- 14 PRISM**
- 15 PRISM ROTATION**
- 16 FOCUS**
- 17 ZOOM**
- 18 RESET+LAMP**

DMX CHANNEL	1	Parameter: PAN msb
DMX CHANNEL	2	Parameter: PAN lsb

DMX CHANNEL	3	Parameter: TILT msb
DMX CHANNEL	4	Parameter: TILT lsb

DMX CHANNEL	5	Parameter: SPEED MOVEMENT
DMX value	Function	
000-010	Standard	
011-025	Fast movement	
026-127	Vector mode from fast to slow	
128-247	Variable time reaction to dmx signal (fast to slow)	
248-255	Silent movement	

DMX CHANNEL	6	Parameter: PAN FAR
DMX value	Function	
000-010	Position mode 540° (standard path)	
011-020	Position mode 360° (1 turn)	
021-030	Position mode 720° (2 turns)	
031-040	Position mode 1080° (3 turns)	
041-050	Position mode 1440° (4 turns)	
051-060	Position mode 1800° (5 turns)	
061-070	Position mode 2160° (6 turns)	
071-080	Position mode 2520° (7 turns)	
081-090	Position mode 2880° (8 turns)	
091-100	Position mode 3240° (9 turns)	
101-110	Position mode 3600° (10 turns)	
111-120	Position mode 360° smart path	
121-182	Forward spin rotation speed from max to min	
183-193	Stop	
194-255	Reverse spin rotation speed from min to max	

DMX CHANNEL	7	Parameter: DIMMER
DMX value	Function	
000-007	Black-out	
008-255	Proportional dimmer	

DMX CHANNEL	8	Parameter: SHUTTER
DMX value	Function	
000-019	Black-out	
020-039	Open	
040-059	Black-out	
060-079	Strobe random speed	
080-089	Strobe speed 1 (0.86 flash/sec)	
090-099	Strobe speed 2 (1.40 flash/sec)	
100-109	Strobe speed 3 (3.78 flash/sec)	
110-119	Strobe speed 4 (5.00 flash/sec)	
120-129	Strobe speed 5 (6.75 flash/sec)	
130-139	Strobe speed 6 (10.00 flash/sec)	
140-149	Flash open speed 1	
150-159	Flash open speed 2	
160-169	Flash open speed 3	
170-179	Flash open speed 4	
180-189	Flash closed speed 1	
190-199	Flash closed speed 2	
200-209	Flash closed speed 3	
210-219	Flash closed speed 4	
220-227	Colours/Gobo in black-out	
228-233	Pan/Tilt in black-out	
234-255	Open	

DMX CHANNEL	9	Parameter: COLOUR
DMX value	Function	
000-004	Colour 1	
005-009	Colour 1-2	
010-014	Colour 2	
015-019	Colour 2-3	
020-024	Colour 3	
025-029	Colour 3-4	
030-034	Colour 4	
035-039	Colour 4-5	
040-044	Colour 5	
045-049	Colour 5-6	
050-054	Colour 6	
055-059	Colour 6-7	
060-064	Colour 7	
065-069	Colour 7-8	
070-074	Colour 8	
075-079	Colour 8-9	
080-084	Colour 9	
085-089	Colour 9-10	
090-094	Colour 10	
095-099	Colour 10-11	
100-104	Colour 11	
105-109	Colour 11-12	
110-114	Colour 12	
115-119	Colour 12-13	
120-124	Colour 13	
125-129	Colour 13-14	
130-134	Colour 14	
135-139	Colour 14-15	
140-144	Colour 15	
145-149	Colour 15-16	
150-154	Colour 16	
155-159	Colour 16-17	
160-164	Colour 17	
165-169	Colour 17-18	
170-174	Colour 18	
175-197	Colour 18-1	
198-200	Right rotation speed 9 max	
201-203	Right rotation speed 8	
204-206	Right rotation speed 7	
207-209	Right rotation speed 6	
210-212	Right rotation speed 5	
213-215	Right rotation speed 4	
216-218	Right rotation speed 3	
219-221	Right rotation speed 2	
222-224	Right rotation speed 1 min	
225-228	Stop	
229-231	Left rotation speed 1 min	
232-234	Left rotation speed 2	
235-237	Left rotation speed 3	
238-240	Left rotation speed 4	
241-243	Left rotation speed 5	
244-246	Left rotation speed 6	
247-249	Left rotation speed 7	
250-252	Left rotation speed 8	
253-255	Left rotation speed 9 max	

DMX CHANNEL	10	Parameter: GOBO
DMX value	Function	
000-020	Open	
021-041	Gobo 1	
042-062	Gobo 2	
063-083	Gobo 3	
084-104	Gobo 4	
105-125	Gobo 5	
126-146	Gobo 6	
147-167	Gobo 7	
168-188	Gobo 8	
189-207	Gobo 9	
208-213	Speed rotation 1 min	
214-219	Speed rotation 2	
220-225	Speed rotation 3	
226-231	Speed rotation 4	
232-237	Speed rotation 5	
238-243	Speed rotation 6	
244-249	Speed rotation 7	
250-255	Speed rotation 8 max	

DMX CHANNEL	11	Parameter: GOBO ROTATION/INDEX
DMX value	Function	
000-127	Proportional index 0°-360°	
128-180	Left rotation	
181-202	Stop	
203-255	Right rotation	

DMX CHANNEL	12	Parameter: FIXED GOBO
DMX value	Function	
000-018	Open	
019-037	Gobo 1	
038-056	Gobo 2	
057-075	Gobo 3	
076-094	Gobo 4	
095-113	Gobo 5	
114-132	Gobo 6	
133-151	Gobo 7	
152-170	Gobo 8	
171-189	Gobo 9	
190-207	Gobo 10	
208-213	Speed rotation 1 min	
214-219	Speed rotation 2	
220-225	Speed rotation 3	
226-231	Speed rotation 4	
232-237	Speed rotation 5	
238-243	Speed rotation 6	
244-255	Speed rotation 7 max	

DMX CHANNEL	13	Parameter: FROST
DMX value	Function	
000-127	No effect	
128-255	Frost inserted	

DMX CHANNEL	14	Parameter: PRISM
DMX value	Function	
000-127	No effect	
128-255	Prism inserted	

DMX CHANNEL	15	Parameter: PRISM ROTATION
DMX value	Function	
000-009	Stop	
010-127	Left rotation from fast to slow	
128-137	Stop	
138-255	Right rotation from slow to fast	

DMX CHANNEL	16	Parameter: FOCUS
DMX value	Function	
000-255	Linear focus	

DMX CHANNEL	17	Parameter: ZOOM
DMX value	Function	
000-255	Linear zoom	

DMX CHANNEL	18	Parameter: RESET + LAMP
DMX value	Function	
000-009	No effect	
010-060	Lamp OFF (3 sec)	
061-129	No effect	
130-179	Lamp ON (3 sec)	
180-200	No effect	
201-239	Internal motor reset	
240-255	Total reset	

21- ROTATING GOBO WHEEL

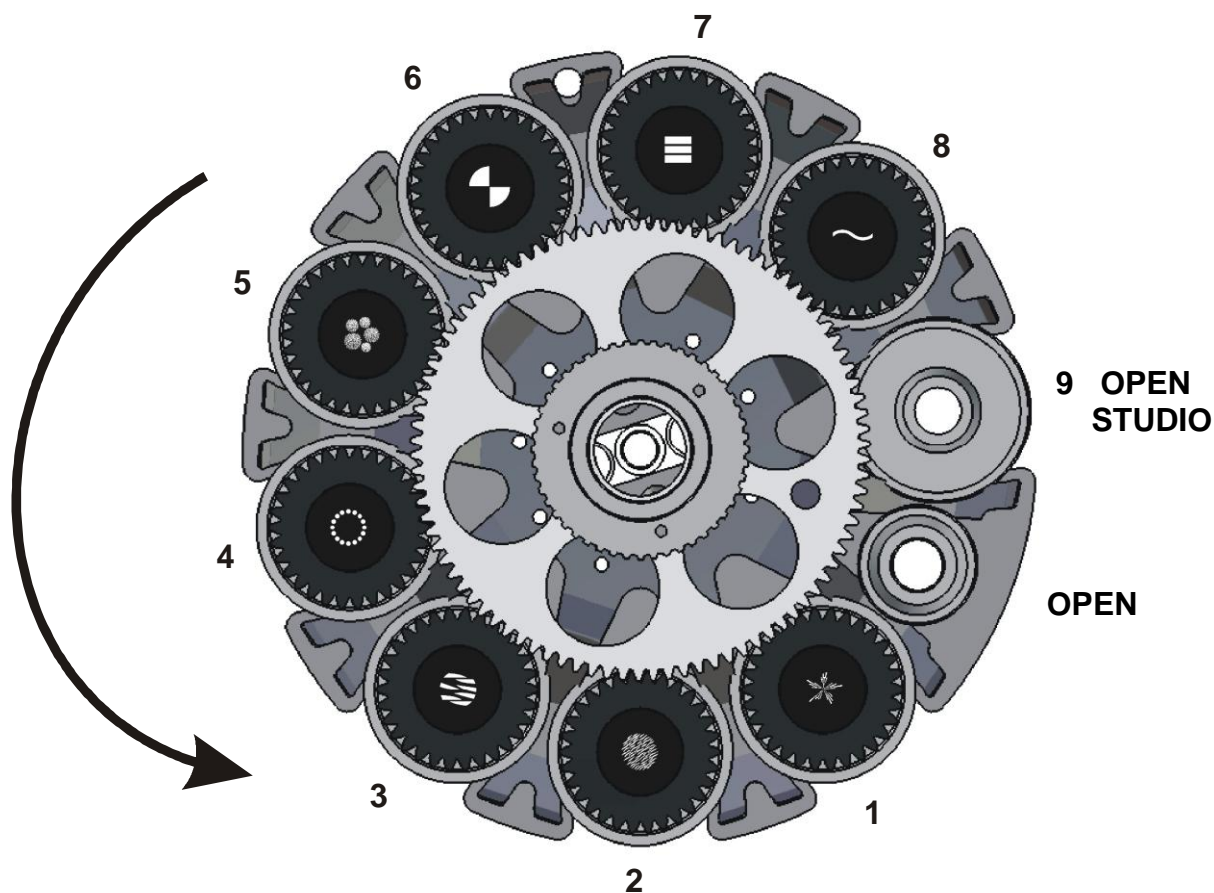

GOBO 1 DICRO



D.T.S. Code:
0516G078

GOBO 2 DICRO



D.T.S. Code:
0516G079

GOBO 3 DICRO



D.T.S. Code:
0516G080

GOBO 4 DICRO



D.T.S. Code:
0516G081

GOBO 5 DICRO



D.T.S. Code:
0516G082

GOBO 6 DICRO



D.T.S. Code:
0516G083

GOBO 7 DICRO



D.T.S. Code:
0516G084

GOBO 8 DICRO



D.T.S. Code:
0516G085

22- FIXED GOBO WHEEL

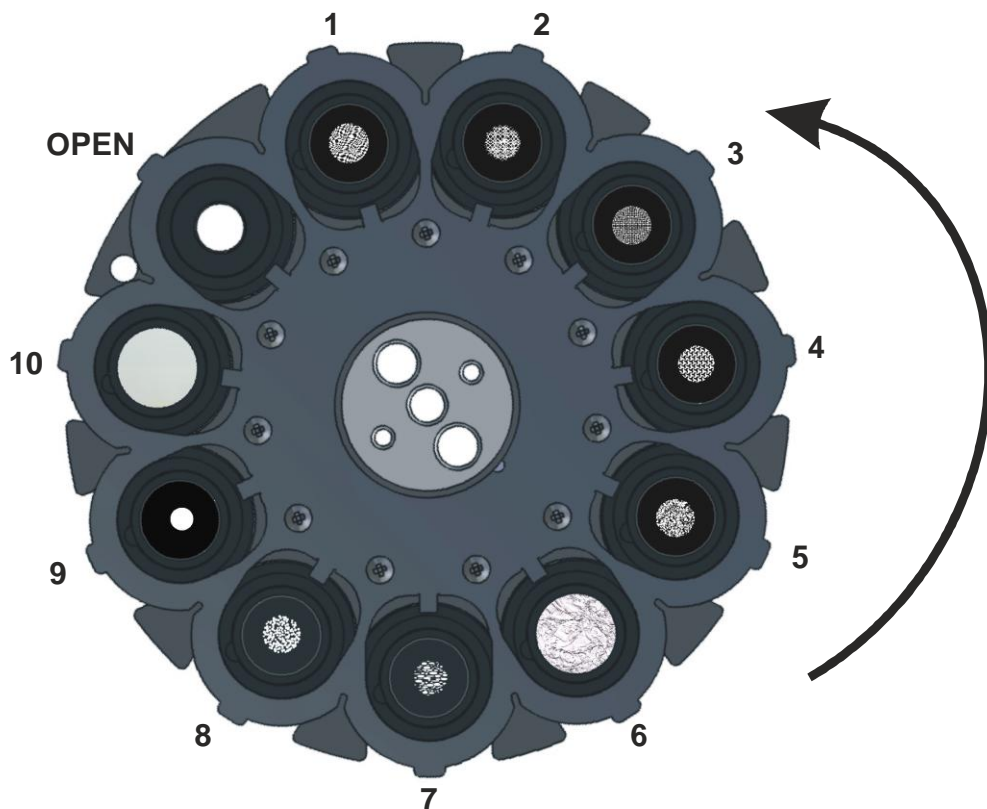

GOBO 1 DICRO

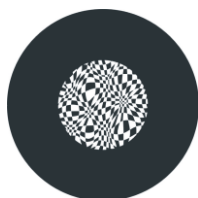

D.T.S. Code:
0516G064

GOBO 2 DICRO



D.T.S. Code:
0516G065

GOBO 3 DICRO

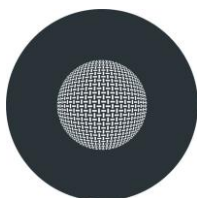

D.T.S. Code:
0516G066

GOBO 4 DICRO



D.T.S. Code:
0516G087

GOBO 5 DICRO



D.T.S. Code:
0516G068

GOBO 6 GLASS



D.T.S. Code:
0516G069

GOBO 7 DICRO



D.T.S. Code:
0516G088

GOBO 8 DICRO



D.T.S. Code:
0516G089

GOBO 9 DICRO



D.T.S. Code:
0516G092

GOBO 10 GLASS

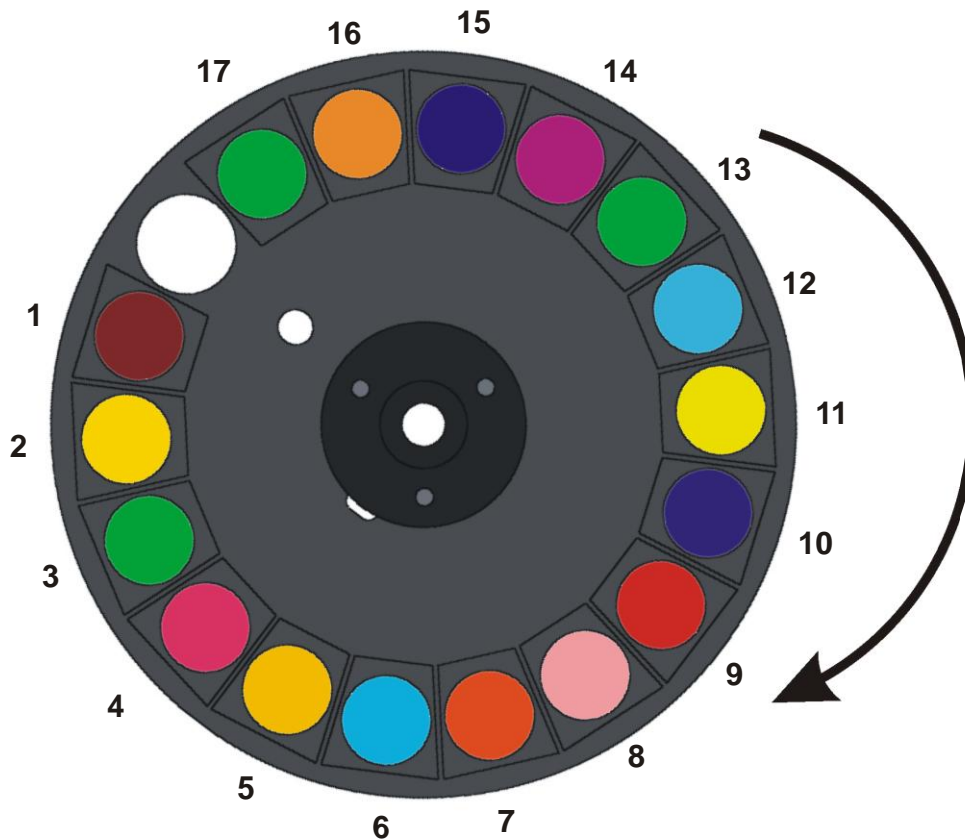

D.T.S. Code:
0516G093

23- COLOUR WHEEL

COLOUR 1
RED



D.T.S. Code:
(0507C059.D14)

COLOUR 2
YELLOW 1



D.T.S. Code:
(0507C065.D14)

COLOUR 3
GREEN



D.T.S. Code:
(0507C068.D14)

COLOUR 4
PINK



D.T.S. Code:
(0507C071.D14)

COLOUR 5
FULL CTO



D.T.S. Code:
(0507C061.D14)

COLOUR 6
FULL CTB



D.T.S. Code:
(0507C060.D14)

COLOUR 7
ORANGE



D.T.S. Code:
(0507C063.D14)

COLOUR 8
LIGHT PINK



D.T.S. Code:
(0507C058.D14)

COLOUR 9
LIGHT RED



D.T.S. Code:
(0507C062.D14)

COLOUR 10
PURPLE



D.T.S. Code:
(0507C072.D14)

COLOUR 11
YELLOW 2



D.T.S. Code:
(0507C066.D14)

COLOUR 12
LIGHT BLUE



D.T.S. Code:
(0507C075.D14)

COLOUR 13
LIGHT GREEN



D.T.S. Code:
(0507C073.D14)

COLOUR 14
MAGENTA



D.T.S. Code:
(0507C074.D14)

COLOUR 15
BLUE



D.T.S. Code:
(0507C070.D14)

COLOUR 16
AMBER



D.T.S. Code:
(0507C064.D14)

COLOUR 17
DARK GREEN



D.T.S. Code:
(0507C067.D14)

The information contained in this publication has been carefully prepared and checked. However, no responsibility will be taken for any errors. All rights are reserved and this document cannot be copied, photocopied or reproduced, in part or completely, without prior written consent from D.T.S.

D.T.S. reserves the right to make any aesthetic, functional or design modifications to any of its products without prior notice. D.T.S. assumes no responsibility for the use or application of the products or circuits described herein.

MADE IN ITALY



The Lighting Company

ISO 9001:2008

D.T.S. quality system
is certified to the
ISO 9001:2008 standard



D.T.S. products are designed
and manufactured at the D.T.S.
plants in Italy



05171221

D.T.S. Illuminazione s.r.l. – Via Fagnano Selve 10-12-14 47843
Misano Adriatico (RN) Italia
Tel.: +39 0541 611131. Fax + 39 0541 611111
info@dts-lighting.it www.dts-lighting.it